



HEAT IS OUR STRENGHT

We design heating plants since 1954. And we achieve innovative systems to supply it. Starting from the first fire tube boiler designed and built in Italy, transportable and monoblock, our story has gone through the world of the heat production's systems with growing success.



GLOBAL THINKING

We have the world as border. We cross it every day with our skills, which include engineering, production, logistics, installation, testing, pre and after sale assistance. We design and accomplish heating systems with an offer of customized products and services integrated in a global plant solution. We are an international company and a flexible and strategic partner. We are the right answer for those people who need heating machineries always more efficient and environmentally friendly.



A STORY OF RECORDS, PASSION AND PERSEVERANCE.

In 1959 was designed the first italian vertical forced circulation boiler for steam's generation from 50 to 500 kg/h, and only three years later was realized the first wet back fire tube boiler. In 1964 the foundation of the "Garioni Macchine Termiche" took place, and it soon became one of the world leaders in the production of industrial boilers. Behind all these successes there was a man, Giacomo Garioni, with his insights and his skills.

In the mid-1990s we expanded our horizons with the fusion between "Garioni Macchine Termiche" and "Naval Caldaie": from this merger the "Garioni Naval" company was born. In 2015 the Garioni Naval brand was acquired by "SVECOM - P.E.", whose main purpose is to continue a successful story, achieving systems and heating plants always more innovative and careful about consumption conscious, energy saving and environment-friendly. We want to offer to our customers the best solutions, with the same passion and perseverance of the origins.





INDEX

STEAM GENERATORS	page 6
THERMAL OIL HEATERS.....	page 36
HOT WATER HEATERS	page 44
SUPERHEATED WATER HEATERS.....	page 58
HEAT RECOVERY HEATERS AND BOILERS	page 64
SYSTEMS FOR COGENERATION	page 66
WATER TUBE BOILERS	page 68
PLANTS ACCESSORIES	page 70
WATER TREATMENT ACCESSORIES	page 72
TECHNICAL ASSISTANCE.....	page 74



STEAM GENERATORS

INDEX

- NG/C page 8
- GPT page 12
- GMT page 16
- GMT/HP page 20
- VPR page 24
- GBP page 28
- MAXI page 32
- GEV page 34



STEAM GENERATORS

Our wide range of steam generators allows us to respond to the market's multiple needs. We design and produce pressure boilers, boilers of various capacities for medium and high pressure, up to generators of great power for the most demanding applications.

All generators are designed, tested, built on the basis of the latest standards and can be certified according to PED, ASME, marine or other regulations depending on the country of installation.

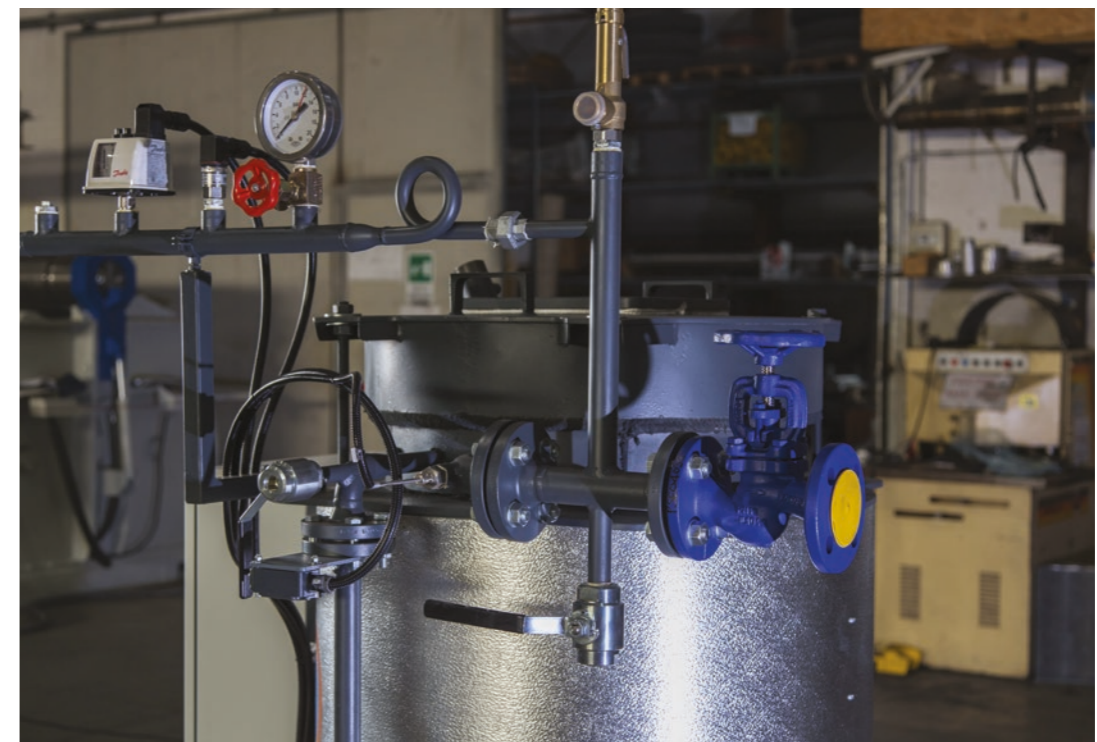

STEAM GENERATORS
NG/C
MODEL

The **NG/C** is a 2-passes steam boiler with dry back. It can produce from 300 to 6,000 kg of steam per hour with a design pressure up to 18 barg.

The accurate sizing of furnace and fire tubes allows the combustion to develop without unburnt particles and with low NOx content, according to the main environmental protection regulations. The high turbulence of the flue gas enhances the heat exchange allowing an excellent efficiency.

This steam generators model can mount any typical burner on the market that allows assistance everywhere and it can be exempted from continuous supervision for 72h when equipped with the relevant kit.

NG/C is the ideal boiler for small and medium industry, designed for the maximum safety and with a small investment cost.

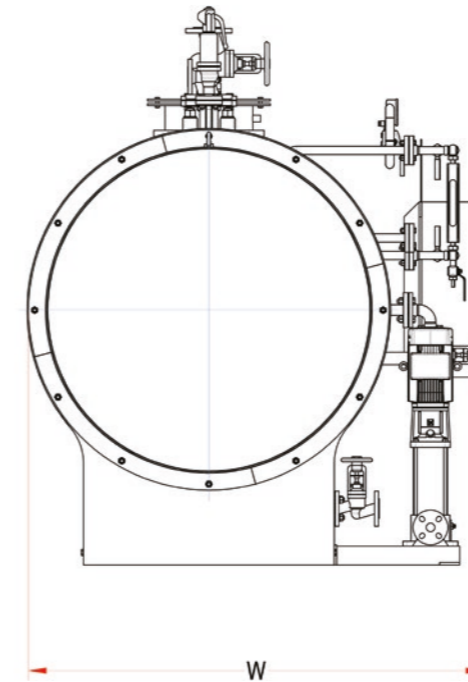

STEAM GENERATORS / NG/C MODEL

- PRODUCT**
 - Steam generators, fire tube, 2 passes, up to 18 barg
- TPOLOGY**
 - Fire tube • 2 passes • Dry back • Through furnace • Horizontal
- CAPACITY**
 - 300 kg/h – 6,000 kg/h

TECHNICAL DATA TWO PASSES SMOKE STEAM BOILER		NG/C					
TYPE		NG/C 300	NG/C 500	NG/C 750	NG/C 1000	NG/C 1500	NG/C 2000
Steam production	kg/h	300	500	750	1,000	1,500	2,000
Steam production (from and at)	kg/h	333	556	833	1,111	1,667	2,222
	lb/h	735	1,224	1,837	2,449	3,673	4,898
Capacity	kcal/h	180,000	300,000	450,000	600,000	900,000	1,200,000
	kW	209	349	523	698	1,047	1,396
Design pressure	bar	12	12	12	12	12	12
	psi	174	174	174	174	174	174
Efficiency without economizer	% ±1	88.0	88.0	88.0	88.0	88.0	88.0
Efficiency with economizer	% ±1	91.7	91.5	91.5	91.5	90.8	91.2
Total internal volume	liters	803	803	1,416	1,416	1,590	1,787
Furnace pressure drop without economizer	mm H2O	30	45	42	65	65	80
Length (burner excluded)	L - mm	2,350	2,350	3,000	3,000	3,300	3,450
Width	W - mm	1,600	1,600	1,600	1,600	1,750	1,800
Height (including safety valves, ...)	H - mm	1,900	1,900	1,950	1,950	2,250	2,300
Empty weight without economizer	kg	1,900	1,900	2,400	2,400	3,700	4,100

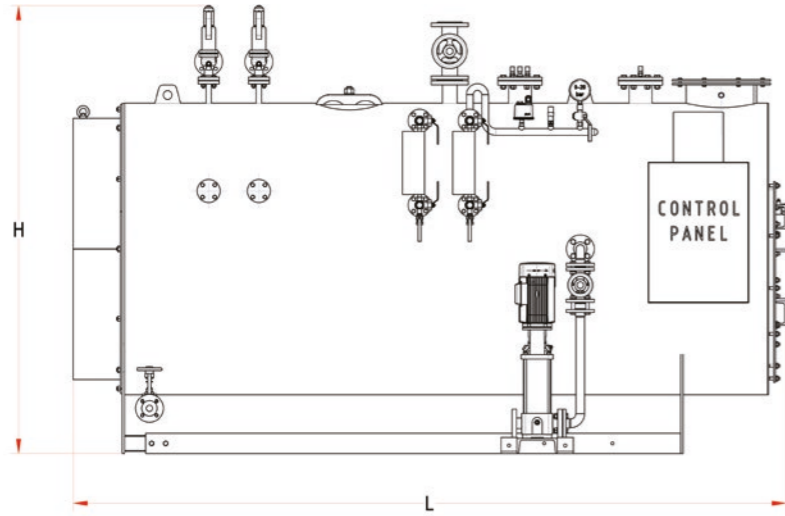

TECHNICAL DATA TWO PASSES SMOKE STEAM BOILER		NG/C				
TYPE		NG/C 2500	NG/C 3000	NG/C 4000	NG/C 5000	NG/C 6000
Steam production	kg/h	2,500	3,000	4,000	5,000	6,000
Steam production (from and at)	kg/h	2,778	3,333	4,444	5,556	6,667
	lb/h	6,122	7,347	9,796	12,244	14,693
Capacity	kcal/h	1,500,000	1,800,000	2,400,000	3,000,000	3,600,000
	kW	1,745	2,093	2,791	3,489	4,187
Design pressure	bar	12	12	12	12	12
	psi	174	174	174	174	174
Efficiency without economizer	% ±1	88.0	88.0	88.0	88.0	88.0
Efficiency with economizer	% ±1	90.8	91.2	91.2	91.0	91.6
Total internal volume	liters	1,995	2,625	3,552	4,745	7,336
Furnace pressure drop without economizer	mm H2O	90	100	115	130	110
Length (burner excluded)	L - mm	3,760	3,760	4,300	4,800	5,400
Width	W - mm	1,850	2,000	2,050	2,200	2,400
Height (including safety valves, ...)	H - mm	2,300	2,400	2,600	2,850	2,900
Empty weight without economizer	kg	5,000	5,200	7,000	9,300	10,000



STEAM GENERATORS

**GPT
MODEL**

The model **GPT** is a 3-passes boiler with wet back wet. It can produce from 3,000 to 25,000 kg of steam per hour with a pressure up to 21 barg. It's used both for liquid and gaseous fuels and it allows a two-position regulation or in a modulating version both on fuel and on feed water.

This model, which represents the most technological-ly advanced on the market today, has been thoroughly engineered to ensure maximum efficiency (up to 95% efficiency using GN-ECO economizers) and minimum NOx emissions, according to the main environmental protection regulations.

The high-volume and high-performance GPT steam generator is recommended for those industries which require flexibility of operation, steam reserve, safety and continuity. It represents the ideal boiler for chemical, pharmaceutical, milk, food and paper industries, and for all installations which demand an absolute guarantee of the components, an impeccable and cured construction, and a sizing that consider harsh operating conditions.

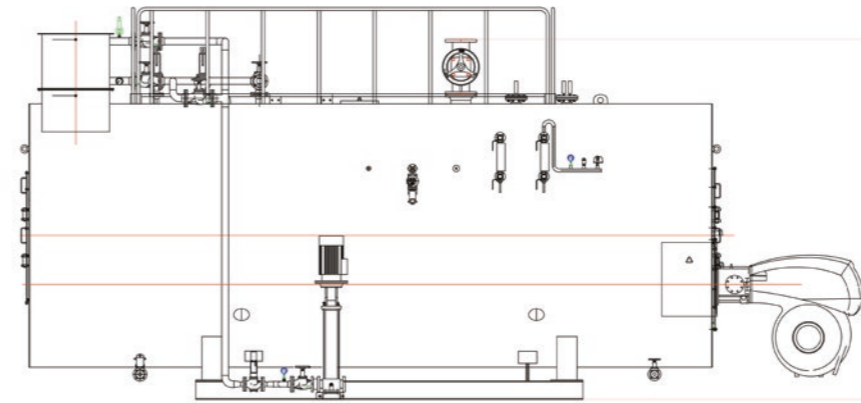

PRODUCT

- Steam generators, fire tube, 3 passes, up to 21barg

TPOLOGY

- Fire tube • 3 passes • Wet back • Through furnace • Horizontal

CAPACITY

- 3,000 kg/h – 25,000 kg/h

**TECHNICAL DATA
THREE PASSES FIRE STEAM BOILER**

GPT

TYPE		GPT 3000	GPT 4000	GPT 5000	GPT 6000	GPT 8000	GPT 10000
Steam production @ FW 85°C	kg/h	3,000	4,000	5,000	6,000	8,000	10,000
Steam production (from and at)	kg/h	3,333	4,444	5,556	6,667	8,889	11,111
	lb/h	7,347	9,796	12,244	14,693	19,591	24,489
Capacity	kcal/h	1,800,000	2,400,000	3,000,000	3,600,000	4,800,000	6,000,000
	kW	2,093	2,791	3,489	4,187	5,582	6,978
	Btu/h	7,142,681	9,523,574	11,904,468	14,285,362	19,047,149	23,808,936
	HP	2,807	3,743	4,679	5,614	7,486	9,357
Design pressure	bar	12	12	12	12	12	12
	psi	174	174	174	174	174	174
Efficiency without economizer	% ±1	90.0	89.1	89.5	89.0	89.0	89.0
Efficiency with economizer (4 rows)	% ±1	92.0	92.0	92.0	93.0	93.0	93.0
Efficiency with economizer (6 rows)	% ±1	94.0	94.0	94.0	94.0	94.0	94.0
Efficiency with economizer (8 rows)	% ±1	95.0	95.0	95.0	95.0	95.0	95.0
Total internal volume	m3	6.77	7.98	7.28	10.79	12.86	16.70
Level capacity	m3	5.68	6.59	6.07	8.81	10.46	15.40
Furnace pressure drop without economizer	mm H2O	80	90	110	115	110	130
Furnace pressure drop with economizer	mm H2O	92	106	126	128	126	147
Length (burner excluded)	mm	4,350	4,750	5,200	5,700	5,882	6,600
Width	mm	2,500	2,500	2,500	2,600	2,850	2,950
Height	mm	2,900	2,900	3,100	3,300	3,500	3,700
Empty weight without economizer	kg	8,500	9,200	9,500	12,100	13,800	17,500
Empty weight with economizer	kg	8,750	9,500	10,000	12,600	14,300	18,000

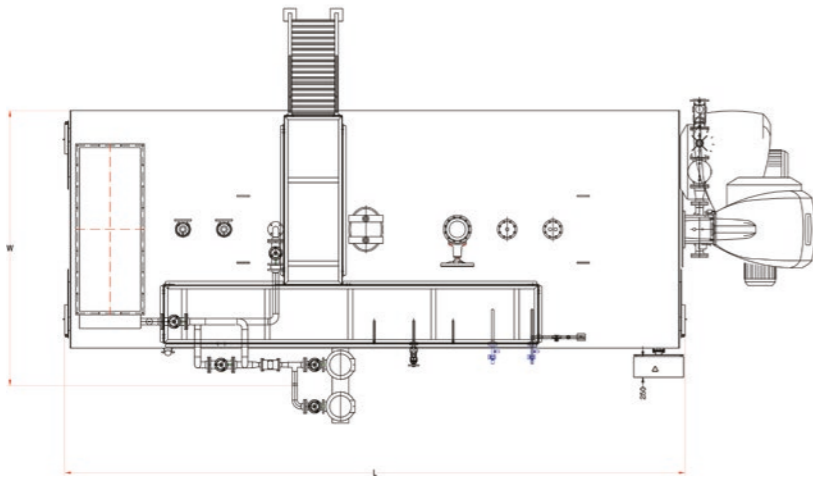

**TECHNICAL DATA
THREE PASSES FIRE STEAM BOILER**
GPT

TYPE		GPT 12000	GPT 15000	GPT 20000	GPT 22000	GPT 25000
Steam production @ FW 85°C	kg/h	12,000	15,000	20,000	22,000	25,000
Steam production (from and at)	kg/h	13,333	16,667	22,222	24,444	27,778
	lb/h	29,387	36,733	48,978	53,876	61,222
Capacity	kcal/h	7,200,000	9,000,000	12,000,000	13,200,000	15,000,000
	kW	8,374	10,467	13,956	15,352	17,445
	Btu/h	28,570,723	35,713,404	47,617,872	52,379,659	59,522,340
	HP	11,229	14,036	18,715	20,586	23,394
Design pressure	bar	12	12	12	12	12
	psi	174	174	174	174	174
Efficiency without economizer	% ±1	90.0	90.0	90.0	90.0	90.0
Efficiency with economizer (4 rows)	% ±1	93.0	93.0	93.0	93.0	93.0
Efficiency with economizer (6 rows)	% ±1	94.0	94.0	94.0	94.0	94.0
Efficiency with economizer (8 rows)	% ±1	95.0	95.0	95.0	95.0	95.0
Total internal volume	m ³	19.30	22.58	32.45	36.36	38.15
Level capacity	m ³	15.30	18.03	25.96	26.89	30.53
Furnace pressure drop without economizer	mm H ₂ O	130	130	150	182	160
Furnace pressure drop with economizer	mm H ₂ O	145	148	170	210	200
Length (burner excluded)	mm	7,000	7,350	8,050	9,000	8,800
Width	mm	3,300	3,500	3,700	4,100	4,000
Height	mm	3,950	4,300	4,550	4,900	4,800
Empty weight without economizer	kg	22,800	30,000	38,000	50,500	46,000
Empty weight with economizer	kg	23,300	30,500	on request	on request	on request



STEAM GENERATORS

**GMT
MODEL**

The horizontal **GMT** and vertical **GMT/V** steam generators are once-through coil boilers. The exchange of heat between water, steam and combustion products, the relative turbulent regimes, the fluid velocities kept as constant as possible by varying the passage sections, allow to obtain a particularly effective thermal exchange.

The thermal load in the combustion chamber is on average below 2,000,000 calories per cubic meter, the specific production (kg of steam per square meter of heated surface) does not reach 70 Kg/sqm.

For installations in Italy, the GMT and GMT / V generators up to size 200 are excluded from the field of application of the UNI-TS 11325 and are exempted from the continuous presence of the licensed driver according to article 29 of the D.M. 05/21/1974. For higher sizes it is possible to provide the configuration suitable for operation without supervision for 72 hours. If necessary, for example in the case of installation of European countries other than Italy, this configuration can also be provided on smaller models.

Maximum power in minimal space, very compact design, high performance, are the peculiar characteristics of these generators that can work both with two flame burners and with modulated regulation.

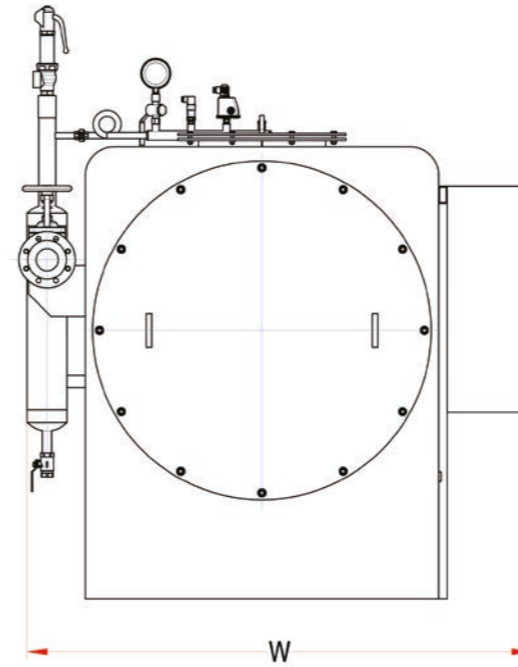

PRODUCT

- Once-through coil steam generators, horizontal or vertical

TYOLOGY

- Once-through coil steam generators • Horizontal or vertical • 3 passes

CAPACITY

- 120 kg/h – 8,000 kg/h

TECHNICAL DATA FORCED CIRCULATION STEAM GENERATORS OPERATION WITHOUT CONTINUOUS SUPERVISION FOR 72 HOURS

GMT HORIZONTAL

TYPE		GMT 12	GMT 20	GMT 30	GMT 40	GMT 50	GMT 60	GMT 80	GMT 100	GMT 120	GMT 150
Steam production	kg/h	120	200	300	400	500	600	800	1,000	1,200	1,500
	lb/h	294	490	735	980	1,224	1,469	1,959	2,449	2,939	3,673
Steam production (from and at)	kg/h	133	222	333	444	556	667	889	1,111	1,333	1,667
	lb/h	294	490	735	980	1,224	1,469	1,959	2,449	2,939	3,673
Capacity	kcal/h	72,000	120,000	180,000	240,000	300,000	360,000	480,000	600,000	720,000	900,000
	kW	84	140	209	279	349	419	558	698	837	1,047
	Btu/h	285,707	476,179	714,268	952,357	1,190,447	1,428,536	1,904,715	2,380,894	2,857,072	3,571,340
	HP	112	187	281	374	468	561	749	936	1,123	1,404
Design pressure	bar	11.76	11.76	11.76	11.76	11.76	11.76	11.76	11.76	11.76	11.76
	psi	171	171	171	171	171	171	171	171	171	171
Efficiency without economizer	% ±1	93.0	92.0	91.0	91.0	90.0	91.0	91.0	90.0	89.0	90.0
Efficiency with economizer	% ±1	96.0	95.0	94.0	94.0	93.0	94.0	94.0	93.0	92.0	93.0
Water content	liters	27	27	27	38	38	72	84	124	124	194
Furnace pressure drop	mm H2O	20	20	30	35	35	40	40	70	90	80
Installation length (burner excluded)	mm	1,750	1,750	1,750	1,750	1,750	2,300	2,300	2,300	2,300	3,350
Installation length (burner included)	mm	2,300	2,300	2,300	2,300	2,300	2,900	2,900	2,900	2,900	4,150
Installation width	mm	1,500	1,500	1,500	1,500	1,500	1,500	1,500	1,500	1,500	1,700
Installation height	mm	1,650	1,650	1,650	1,650	1,650	1,700	1,700	1,750	1,750	2,000
Empty weight (burner excluded)	kg	750	750	750	850	850	1,100	1,100	1,250	1,250	1,800



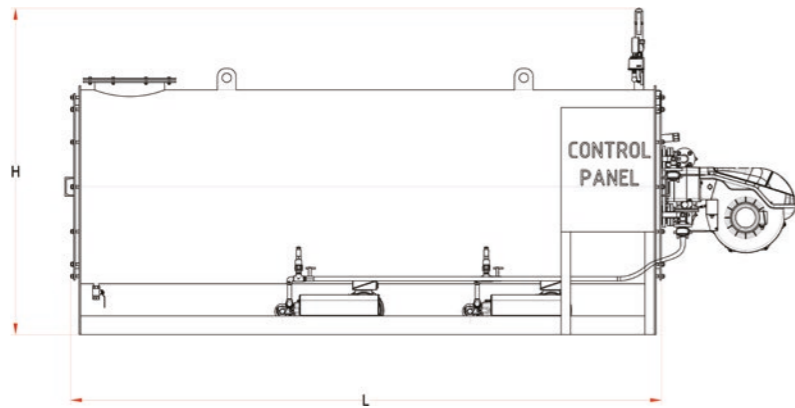

TECHNICAL DATA FORCED CIRCULATION STEAM GENERATORS OPERATION WITHOUT CONTINUOUS SUPERVISION FOR 72 HOURS						GMT HORIZONTAL				
TYPE		GMT 180	GMT 200	GMT 250	GMT 300	GMT 400	GMT 500	GMT 600	GMT 700	GMT 800
Steam production	kg/h	1,800	2,000	2,500	3,000	4,000	5,000	6,000	7,000	8,000
Steam production (from and at)	kg/h	2,000	2,222	2,778	3,333	4,444	5,556	6,667	7,778	8,889
	lb/h	4,408	4,898	6,122	7,347	9,796	12,244	14,693	17,142	19,591
Capacity	kcal/h	1,080,000	1,200,000	1,500,000	1,800,000	2,400,000	3,000,000	3,600,000	4,200,000	4,800,000
	kW	1,256	1,396	1,745	2,093	2,791	3,489	4,187	4,885	5,582
	Btu/h	4,285,608	4,761,787	5,952,234	7,142,681	9,523,574	11,904,468	14,285,362	16,666,255	19,047,149
	HP	1,684	1,871	2,339	2,807	3,743	4,679	5,614	6,550	7,486
Design pressure	bar	11.76	11.76	11.76	11.76	12.00	12.00	12.00	12.00	12.00
	psi	171	171	171	171	174	174	174	174	174
Efficiency without economizer	% ±1	90.0	89.0	90.0	89.0	89.0	90.0	90.0	90.0	90.0
Efficiency with economizer	% ±1	93.0	92.0	93.0	92.0	92.0	93.0	93.0	93.0	93.0
Water content	liters	250	250	250	250	570	899	1,095	1,250	1,196
Furnace pressure drop	mm H2O	80	80	90	90	100	110	115	120	125
Installation length (burner excluded)	mm	3,350	3,350	3,700	4,100	4,400	4,750	5,150	5,400	5,550
Installation length (burner included)	mm	4,150	4,150	4,800	5,200	5,750	5,850	6,300	6,600	6,800
Installation width	mm	1,700	1,700	1,850	1,850	2,200	2,550	2,500	3,200	3,200
Installation height	mm	2,100	2,100	2,100	2,200	2,200	2,700	2,600	2,500	2,500
Empty weight (burner excluded)	kg	2,100	2,100	2,900	3,000	3,850	6,600	7,000	7,700	9,000

TECHNICAL DATA FORCED CIRCULATION STEAM GENERATORS OPERATION WITHOUT CONTINUOUS SUPERVISION FOR 72 HOURS							GMT VERTICAL				
TYPE		GMT/V 12	GMT/V 20	GMT/V 30	GMT/V 40	GMT/V 50	GMT/V 60	GMT/V 80	GMT/V 100	GMT/V 120	GMT/V 150
Steam production	kg/h	120	200	300	400	500	600	800	1,000	1,200	1,500
Steam production (from and at)	kg/h	133	222	333	444	556	667	889	1,111	1,333	1,667
	lb/h	294	490	735	980	1,224	1,469	1,959	2,449	2,939	3,673
Capacity	kcal/h	72,000	120,000	180,000	240,000	300,000	360,000	480,000	600,000	720,000	900,000
	kW	84	140	209	279	349	419	558	698	837	1,047
	Btu/h	285,707	476,179	714,268	952,357	1,190,447	1,428,536	1,904,715	2,380,894	2,857,072	3,571,340
	HP	112	187	281	374	468	561	749	936	1,123	1,404
Design pressure	bar	11.76	11.76	11.76	11.76	11.76	11.76	11.76	11.76	11.76	11.76
	psi	171	171	171	171	171	171	171	171	171	171
Efficiency without economizer	% ±1	93.0	92.0	91.0	91.0	90.0	91.0	91.0	90.0	89.0	90.0
Efficiency with economizer	% ±1	96.0	95.0	94.0	94.0	93.0	94.0	94.0	93.0	92.0	93.0
Water content	liters	27	27	27	38	38	72	84	124	124	194
Furnace pressure drop	mm H2O	20	20	30	35	35	40	40	70	90	80
Installation width	mm	1,000	1,000	1,000	1,000	1,000	1,250	1,250	1,250	1,250	1,550
Installation depth	mm	1,375	1,375	1,375	1,250	1,250	1,500	1,500	1,550	1,550	1,650
Installation height (burner excluded)	mm	2,050	2,050	2,050	2,050	2,050	2,050	2,200	2,600	2,600	3,100
Empty weight (burner excluded)	kg	700	700	700	750	750	1,050	1,100	1,250	1,250	1,800

TECHNICAL DATA FORCED CIRCULATION STEAM GENERATORS OPERATION WITHOUT CONTINUOUS SUPERVISION FOR 72 HOURS						GMT VERTICAL				
TYPE		GMT/V 180	GMT/V 200	GMT/V 250	GMT/V 300	GMT/V 400	GMT/V 500	GMT/V 600	GMT/V 700	GMT/V 800
Steam production	kg/h	1,800	2,000	2,500	3,000	4,000	5,000	6,000	7,000	8,000
Steam production (from and at)	kg/h	2,000	2,222	2,778	3,333	4,444	5,556	6,667	7,778	8,889
	lb/h	4,408	4,898	6,122	7,347	9,796	12,244	14,693	17,142	19,591
Capacity	kcal/h	1,080,000	1,200,000	1,500,000	1,800,000	2,400,000	3,000,000	3,600,000	4,200,000	4,800,000
	kW	1,256	1,396	1,745	2,093	2,791	3,489	4,187	4,885	5,582
	Btu/h	4,285,608	4,761,787	5,952,234	7,142,681	9,523,574	11,904,468	14,285,362	16,666,255	19,047,149
	HP	1,684	1,871	2,339	2,807	3,743	4,679	5,614	6,550	7,486
Design pressure	bar	11.76	11.76	11.76	11.76	12.00	12.00	12.00	12.00	12.00
	psi	171	171	171	171	174	174	174	174	174
Efficiency without economizer	% ±1	90.0	89.0	90.0	89.0	89.0	90.0	90.0	90.0	90.0
Efficiency with economizer	% ±1	93.0	92.0	93.0	92.0	92.0	93.0	93.0	93.0	93.0
Water content	liters	250	250	250	250	570	899	1,095	1,250	1,196
Furnace pressure drop	mm H2O	80	80	90	90	100	110	115	120	125
Installation width	mm	1,600	1,600	1,700	1,700	2,000	2,450	2,450	2,900	2,900
Installation depth	mm	1,700	1,700	1,600	1,600	1,850	2,150	2,150	2,600	2,600
Installation height (burner excluded)	mm	3,350	3,350	3,800	4,050	4,300	5,000	5,250	5,800	5,800
Empty weight (burner excluded)	kg	1,800	1,800	2,700	2,800	3,800	6,200	6,300	7,700	9,000



STEAM GENERATORS
**GMT/HP
MODEL**

Many technological processes, especially in the food industry, require the use of heat producing systems capable of achieving high temperatures (above 250 °C).

To get so high temperatures, many industries rely on diathermic oil boilers, but it is not allowed in the food sector due to the intrinsic danger of pollution. The solution is therefore to use high pressure steam and, for this reason, the **GMT/HP** steam generator represents the ideal system.

These generators, with gas or liquid fuel, operate without condensate drain, water treatment and circulation pump. They are easy to install and they don't have any collectors or special connections. The version AR includes a smoke/air exchanger that preheats the combustion air at the expense of the residual heat of the flue gases, improving the efficiency of the equipment.

We guarantee the necessary technical, pre and post sales service in every part of the world.

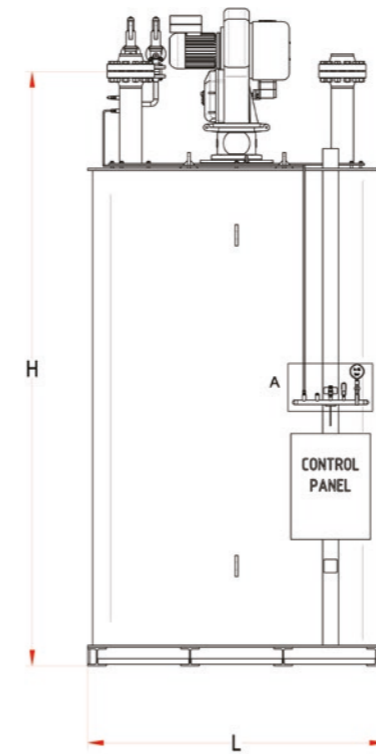

PRODUCT

- High pressure steam generator (up to 100 barg), with natural circulation

TYPOLGY

- Coil • 3 passes • Through furnace • Vertical • Designed for high pressure • Natural circulation systems

CAPACITY

- 100,000 kcal/h – 5,000,000 kcal/h

TECHNICAL DATA HIGH PRESSURE STEAM GENERATOR OPERATION WITHOUT CONTINUOUS SUPERVISION FOR 72 HOURS							GMT/HP			
TYPE		GMT/HP 100	GMT/HP 200	GMT/HP 300	GMT/HP 400	GMT/HP 500	GMT/HP 600	GMT/HP 800	GMT/HP 1000	GMT/HP 1250
Operating pressure	bar	90	90	90	90	90	90	90	90	90
Capacity	kcal/h	100,000	200,000	300,000	400,000	500,000	600,000	800,000	1,000,000	1,250,000
	kW	116	233	349	465	582	698	930	1,163	1,454
	Btu/h	396,816	793,631	1,190,447	1,587,262	1,984,078	2,380,894	3,174,525	3,968,156	4,960,195
Design pressure	HP	156	312	468	624	780	936	1,248	1,560	1,949
	bar	110	110	110	110	110	110	110	110	110
	psi	1,595	1,595	1,595	1,595	1,595	1,595	1,595	1,595	1,595
Water content	liters	58	66	127	127	290	290	557	557	1,239
Furnace pressure drop	mm H2O	20	30	35	40	45	50	75	80	85
Installation depth	mm	1,730	1,630	1,760	1,760	1,980	1,980	2,325	2,325	2,790
Installation width	mm	1,150	1,150	1,250	1,250	1,500	1,500	1,800	1,800	2,250
Installation height (burner excluded)	mm	2,255	2,265	2,805	2,805	3,055	3,055	3,325	3,325	4,335
Empty weight (burner excluded)	kg	1,500	1,500	1,700	1,700	2,500	2,600	3,900	3,900	7,500

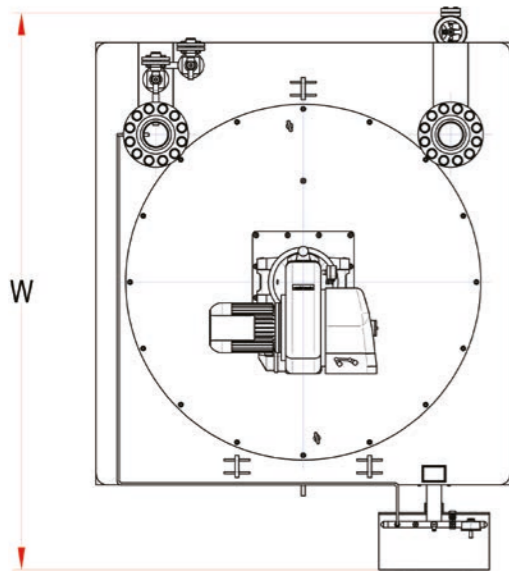

**TECHNICAL DATA HIGH PRESSURE STEAM GENERATOR
OPERATION WITHOUT CONTINUOUS SUPERVISION FOR 72**
GMT/HP

TYPE		GMT/HP 1500	GMT/HP 1750	GMT/HP 2000	GMT/HP 2500	GMT/HP 3000	GMT/HP 3600	GMT/HP 4000	GMT/HP 5000
Operating pressure	bar	90	90	90	90	90	90	90	90
Capacity	kcal/h	1,500,000	1,750,000	2,000,000	2,500,000	3,000,000	3,600,000	4,000,000	5,000,000
	kW	1,745	2,035	2,326	2,908	3,489	4,187	4,652	5,815
	Btu/h	5,952,234	6,944,273	7,936,312	9,920,390	11,904,468	14,285,362	15,872,624	19,840,780
	HP	2,339	2,729	3,119	3,899	4,679	5,614	6,238	7,798
Design pressure	bar	110	110	110	110	110	110	110	110
	psi	1,595	1,595	1,595	1,595	1,595	1,595	1,595	1,595
Water content	liters	1,239	1,389	1,481	1,330	1,566	2,150	on request	on request
Furnace pressure drop	mm H2O	90	90	90	100	110	110	on request	on request
Installation depth	mm	2,790	2,795	2,830	2,830	2,830	3,160	on request	on request
Installation width	mm	2,250	2,250	2,250	2,250	2,250	2,700	on request	on request
Installation height (burner excluded)	mm	4,335	4,625	4,925	5,185	5,300	6,040	on request	on request
Empty weight (burner excluded)	kg	7,500	8,400	8,900	9,500	9,800	13,400	on request	on request



STEAM GENERATORS

VPR
MODEL

The tubeless generators of the **VPR** series are simple and effective solutions for steam generation. They produce from 50 to 500 kg of steam per hour and they can work with gas or diesel, two-stage or modulating burners. For the installations in Italy, some models are completely exempt from the obligation of a continuous supervision.

Their special free-floating water-gap structure guarantees the safety and reliability they have found and finds a broad consensus among customers. These steam generators are recommended for the packaging industry, for laundry, ironing, dyeing, saunas, for heating tanks and for all industrial processes that do not need large steam production.

The machines are supplied in a single-block version, complete with all the accessories for the operation, with the electrical cabinet and, at the request, with the burner and the condensate recovery tank.

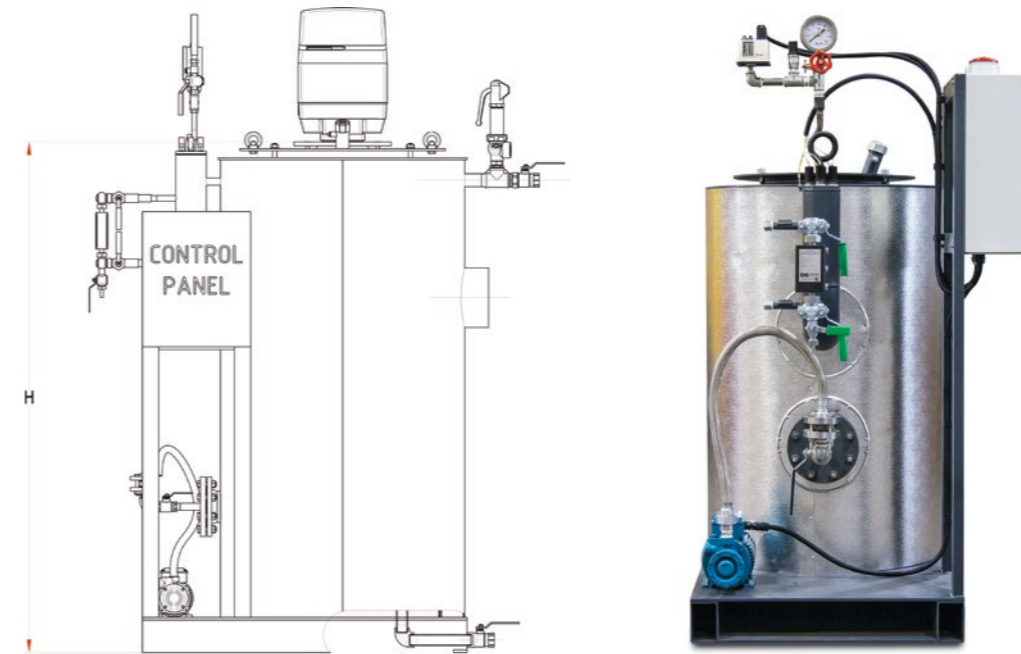

PRODUCT

- Tubeless steam generators

TIPOLOGY

- Tubeless • 2 passes • Dry-back • Vertical

CAPACITY

- 50 kg/h - 500 kg/h

TECHNICAL DATA TUBLESS STEAM BOILER OPERATION WITHOUT CONTINUOUS SUPERVISION FOR 24 HOURS							VPR			
TYPE		VPR 50	VPR 50	VPR 50	VPR 80	VPR 80	VPR 80	VPR 120	VPR 120	VPR 120
Design pressure	bar	6	8	10	6	8	10	6	5	10
	psi	87	116	145	87	116	145	87	73	145
Steam production	kg/h	50	50	50	80	80	80	120	120	120
	lb/h	110	110	110	176	176	176	264	264	264
Capacity	kcal/h	30,000	30,000	30,000	48,000	48,000	48,000	72,000	72,000	72,000
	kW	35	35	35	56	56	56	84	84	84
	Btu/h	119,045	119,045	119,045	190,471	190,471	190,471	285,707	285,707	285,707
	HP	47	47	47	75	75	75	112	112	112
Efficiency	% ±1	90.0	90.0	90.0	90.0	90.0	90.0	90.0	90.0	90.0
Total internal volume	liters	60	60	60	60	60	60	60	60	60
Level capacity	liters	45	45	45	45	45	45	45	45	45
Furnace pressure drop	mm H2O	10	10	10	12	12	12	15	15	15
Length	mm	850	850	850	850	850	850	850	850	850
Width	mm	1,600	1,600	1,600	1,600	1,600	1,600	1,600	1,600	1,600
Height without burner	mm	1,700	1,700	1,700	1,700	1,700	1,700	1,700	1,700	1,700
Empty weight without burner	kg	625	625	625	625	625	625	625	625	625

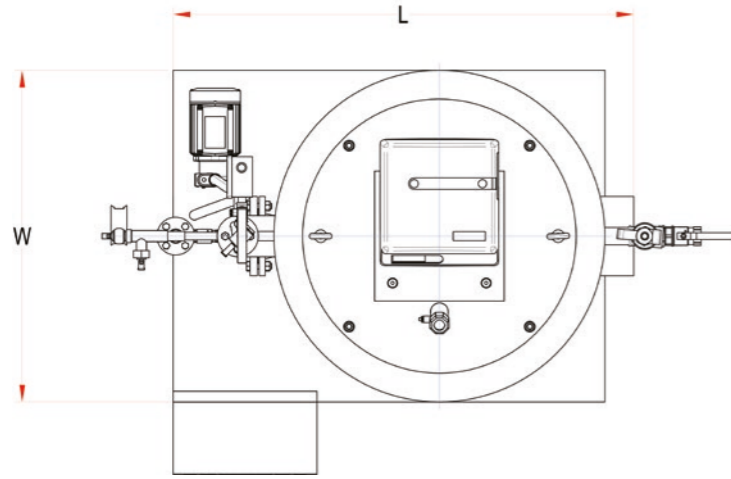
**TECHNICAL DATA TUBLESS STEAM BOILER
OPERATION WITHOUT CONTINUOUS SUPERVISION FOR 24 HOURS**
VPR

TYPE		VPR 160	VPR 160	VPR 220	VPR 220	VPR 270	VPR 270	VPR 330	VPR 330	VPR 500
Design pressure	bar	6	10	6	10	6	10	6	10	10
	psi	87	145	87	145	87	145	87	145	145
Steam production	kg/h	160	160	220	220	270	270	330	330	500
	lb/h	353	353	485	485	595	595	727	727	1,102
Capacity	kcal/h	96,000	96,000	132,000	132,000	162,000	162,000	198,000	198,000	300,000
	kW	112	112	154	154	188	188	230	230	349
	Btu/h	380,943	380,943	523,797	523,797	642,841	642,841	785,695	785,695	1,190,447
	HP	150	150	206	206	253	253	309	309	468
Efficiency	% ±1	90.0	90.0	90.0	90.0	90.0	90.0	90.0	90.0	88.0
Total internal volume	liters	77	77	77	77	99	99	99	99	460
Level capacity	liters	62	62	62	62	79	79	79	79	385
Furnace pressure drop	mm H2O	20	20	27	27	42	42	55	55	60
Length	mm	850	850	850	850	900	900	900	900	1,250
Width	mm	1,600	1,600	1,600	1,600	1,650	1,650	1,650	1,650	2,000
Height without burner	mm	2,000	2,000	2,000	2,000	2,300	2,300	2,300	2,300	2,600
Empty weight without burner	kg	725	725	725	725	950	950	950	950	1,500

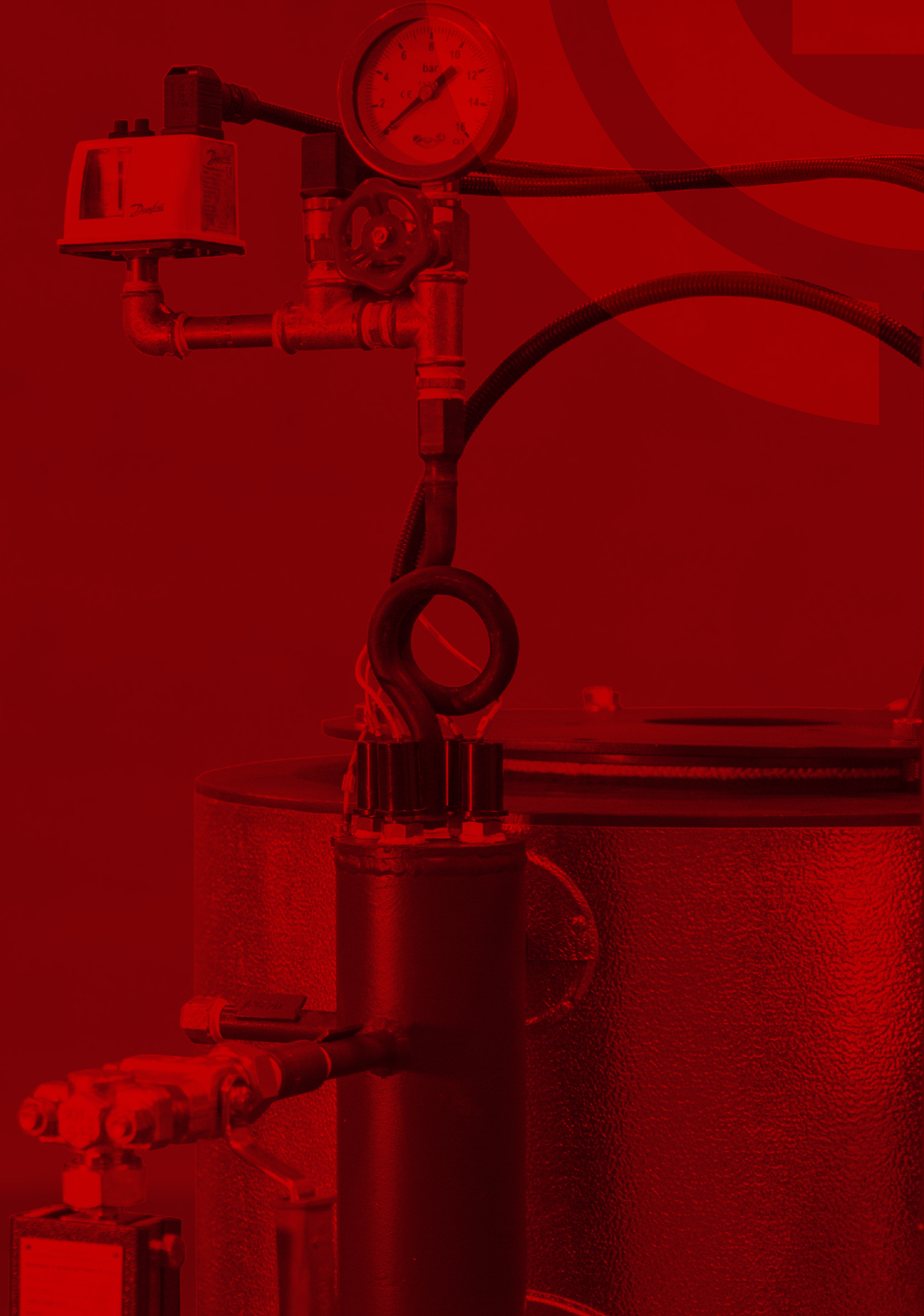

STEAM GENERATORS

**GBP
MODEL**

The **GBP** steam generator is a system working with pressurized combustion for industrial use, which allows you to produce between 100 and 3,000 kg of steam. It is available in two versions: design pressure 0.5 barg and design pressure 0.98 barg.

The 0.5 barg version is excluded from the scope of the PED directive and for this reason, in Italy, it does not require continuous supervision, commissioning or periodic inspections. The 0.98 barg version is excluded from the scope of application of UNITS11325-3 and is exempted, in Italy, by the continuous presence of the licensed driver according to article 39 of D.M.21/05/1974.

It is built according to the most advanced techniques, is equipped with a large flame inversion furnace, cylindrical, closed to the back end. The combustion gases, thanks to the pressurization that takes place in the combustion chamber, return to the front to take the tube bundle and be conveyed into the smoke collection chamber and then to the chimney.

The GBP boiler works with any type of fuel, liquid or gaseous, and is delivered complete, ready to the operation, equipped with the equipment of protection and security.

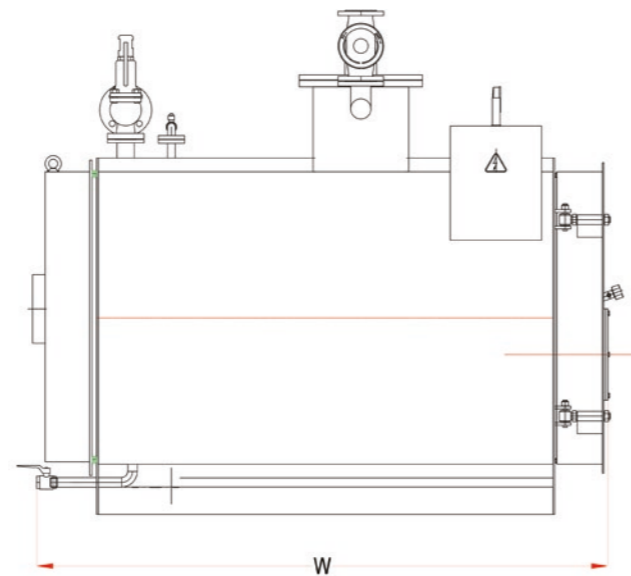
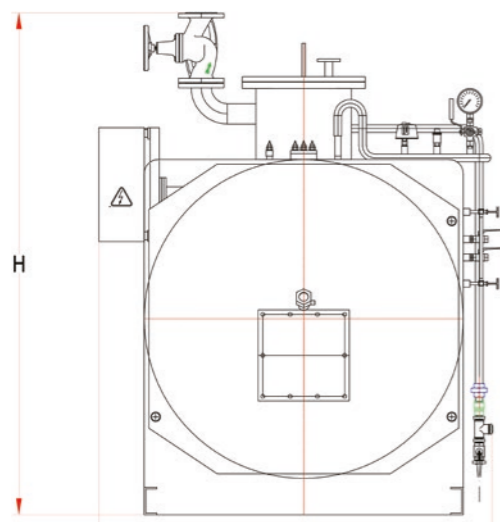

PRODUCT

- Low pressure steam generators

TYOLOGY

- Fire tubes • 3 passes • Wet back • Reverse flame • Horizontal • Low pressure

CAPACITY

- 100 kg/h - 3,000 kg/h

TECHNICAL DATA LOW PRESSURE STEAM BOILER **GBP 0,5 BAR**

TYPE		GBP 100	GBP 150	GBP 200	GBP 250	GBP 300	GBP 400	GBP 500	GBP 600	GBP 800
Steam production	kg/h	100	150	200	250	300	400	500	600	800
	lb/h	220	331	441	551	661	882	1,102	1,322	1,763
Capacity	kcal/h	60,000	90,000	120,000	150,000	180,000	240,000	300,000	360,000	480,000
	kW	70	105	140	174	209	279	349	419	558
	Btu/h	238,047	357,070	476,093	595,116	714,140	952,186	1,190,233	1,428,279	1,904,372
	HP	94	140	187	234	281	374	468	561	748
Design pressure	bar	0.5	0.5	0.5	0.5	0.5	0.5	0.5	0.5	0.5
	psi	7	7	7	7	7	7	7	7	7
Efficiency	% ±1	88.0	88.0	88.0	88.0	88.0	88.0	88.0	88.0	88.0
Total internal volume	liters	165	229	229	271	319	469	545	681	867
Furnace pressure drop	mm H2O	25	25	25	25	25	27	32	36	40
Length (burner excluded)	mm	1,129	1,380	1,380	1,440	1,675	1,825	1,950	1,925	2,250
Length (burner included)	mm	1,679	1,930	1,930	1,990	2,225	2,375	2,500	2,545	3,130
Width (including level indicators, ...)	mm	850	910	910	920	930	1,000	1,050	1,100	1,150
Height (including safety valves, ...)	mm	1,490	1,540	1,540	1,565	1,750	1,800	1,900	2,000	2,100
Empty weight	kg	300	450	450	550	570	820	900	1,000	1,100

TECHNICAL DATA LOW PRESSURE STEAM BOILER **GBP 0,5 BAR**

TYPE		GBP 900	GBP 1000	GBP 1200	GBP 1400	GBP 1600	GBP 2000	GBP 2500	GBP 3000
Steam production	kg/h	900	1,000	1,200	1,400	1,600	2,000	2,500	3,000
	lb/h	1,984	2,204	2,645	3,086	3,526	4,408	5,510	6,612
Capacity	kcal/h	540,000	600,000	720,000	840,000	960,000	1,200,000	1,500,000	1,800,000
	kW	628	698	837	977	1,116	1,395	1,744	2,093
	Btu/h	2,142,419	2,380,465	2,856,558	3,332,651	3,808,744	4,760,930	5,951,163	7,141,395
	HP	842	936	1,123	1,310	1,497	1,871	2,339	2,807
Design pressure	bar	0.5	0.5	0.5	0.5	0.5	0.5	0.5	0.5
	psi	7	7	7	7	7	7	7	7
Efficiency	% ±1	88.0	88.0	88.0	88.0	88.0	88.0	88.0	88.0
Total internal volume	liters	938	938	1,159	1,353	1,678	1,931	2,720	on request
Furnace pressure drop	mm H2O	40	42	50	56	75	85	105	on request
Length (burner excluded)	mm	2,250	2,250	2,500	2,540	2,600	2,625	3,035	on request
Length (burner included)	mm	3,130	3,130	3,380	3,420	3,500	3,515	3,925	on request
Width (including level indicators, ...)	mm	1,250	1,250	1,510	1,580	1,450	1,835	1,910	on request
Height (including safety valves, ...)	mm	2,150	2,150	1,850	1,942	2,930	3,080	3,210	on request
Empty weight	kg	1,350	1,350	1,750	1,950	2,500	3,250	3,550	on request

TECHNICAL DATA LOW PRESSURE STEAM BOILER			GBP 0,98 BAR					
TYPE		GBP 100	GBP 150	GBP 200	GBP 250	GBP 300	GBP 400	GBP 600
Steam production	kg/h	165	250	333	416	500	666	1,000
	lb/h	364	551	734	917	1,102	1,468	2,204
Capacity	kcal/h	99,000	150,000	200,000	250,000	300,000	400,000	600,000
	kW	115	174	233	291	349	465	698
	Btu/h	392,777	595,116	793,488	991,860	1,190,233	1,586,977	2,380,465
	HP	154	234	312	390	468	624	936
Design pressure	bar	1	1	1	1	1	1	1
	psi	15	15	15	15	15	15	15
Efficiency	%	88.0	88.0	88.0	88.0	88.0	88.0	88.0
Total internal volume	liters	410	805	805	830	1,050	1,210	1,740
Level capacity	liters	250	515	515	531	705	815	1,175
Furnace pressure drop	mm H2O	15	15	18	20	27	32	42
Length (burner excluded)	mm	1,670	1,800	1,800	2,050	2,010	2,300	2,600
Width (including level indicators, ...)	mm	1,140	1,300	1,300	1,300	1,620	1,910	1,775
Height (including safety valves, ...)	mm	1,510	1,550	1,550	1,550	2,090	2,090	2,340
Empty weight	kg	1,100	1,100	1,600	1,750	1,750	2,000	2,200

TECHNICAL DATA LOW PRESSURE STEAM BOILER			GBP 0,98 BAR						
TYPE		GBP 700	GBP 800	GBP 900	GBP 1000	GBP 1200	GBP 1500	GBP 1800	GBP 2200
Steam production	kg/h	1,166	1,333	1,500	1,666	2,000	2,500	3,000	3,666
	lb/h	2,570	2,938	3,306	3,672	4,408	5,510	6,612	8,080
Capacity	kcal/h	700,000	800,000	900,000	1,000,000	1,200,000	1,500,000	1,800,000	2,200,000
	kW	814	930	1,047	1,163	1,395	1,744	2,093	2,558
	Btu/h	2,777,209	3,173,953	3,570,698	3,967,442	4,760,930	5,951,163	7,141,395	8,728,372
	HP	1,092	1,247	1,403	1,559	1,871	2,339	2,807	3,430
Design pressure	bar	1	1	1	1	1	1	1	1
	psi	15	15	15	15	15	15	15	15
Efficiency	%	88.0	88.0	88.0	88.0	88.0	88.0	88.0	88.0
Total internal volume	liters	2,225	2,225	2,530	2,530	3,020	3,890	4,150	on request
Level capacity	liters	1,480	1,480	1,695	1,695	2,050	2,790	3,290	on request
Furnace pressure drop	mm H2O	46	50	56	75	85	105	115	on request
Length (burner excluded)	mm	2,550	2,550	2,835	2,835	3,050	3,350	3,350	on request
Width (including level indicators, ...)	mm	1,550	1,550	1,935	1,935	2,000	2,000	2,000	on request
Height (including safety valves, ...)	mm	1,850	1,850	2,500	2,500	1,850	2,125	2,125	on request
Empty weight	kg	2,600	2,600	3,100	3,100	3,100	3,600	3,900	on request

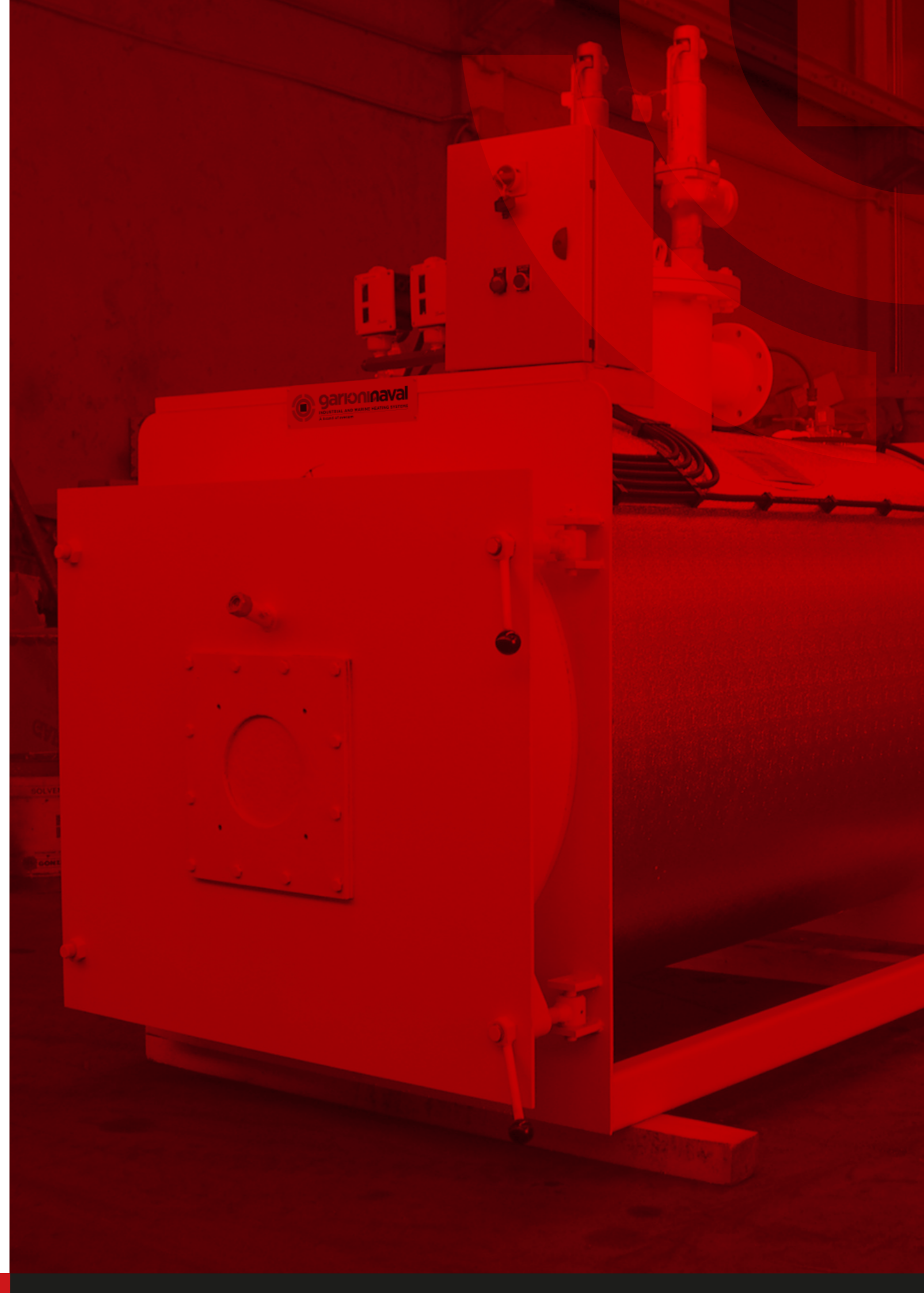

STEAM GENERATORS

**MAXI
MODEL**

Electric and automatic steam generator, available with variable power from 15 to 180 kW, made with one or more electrical resistors. Project pressure up to 10 barg. The **MAXI** generator can produce from a minimum of 9 Kg/h to a maximum of 170 Kg/h of steam at an operating pressure of 7 + 8 barg. It can be supplied directly from the water net or from a special stainless-steel tank.

It is the ideal boiler for laboratories and small uses. It is particularly indicated for operating flat glossy presses (used for cotton wool) or, equipped with a special steam gun, it is suitable for grading and ironing of the fur.

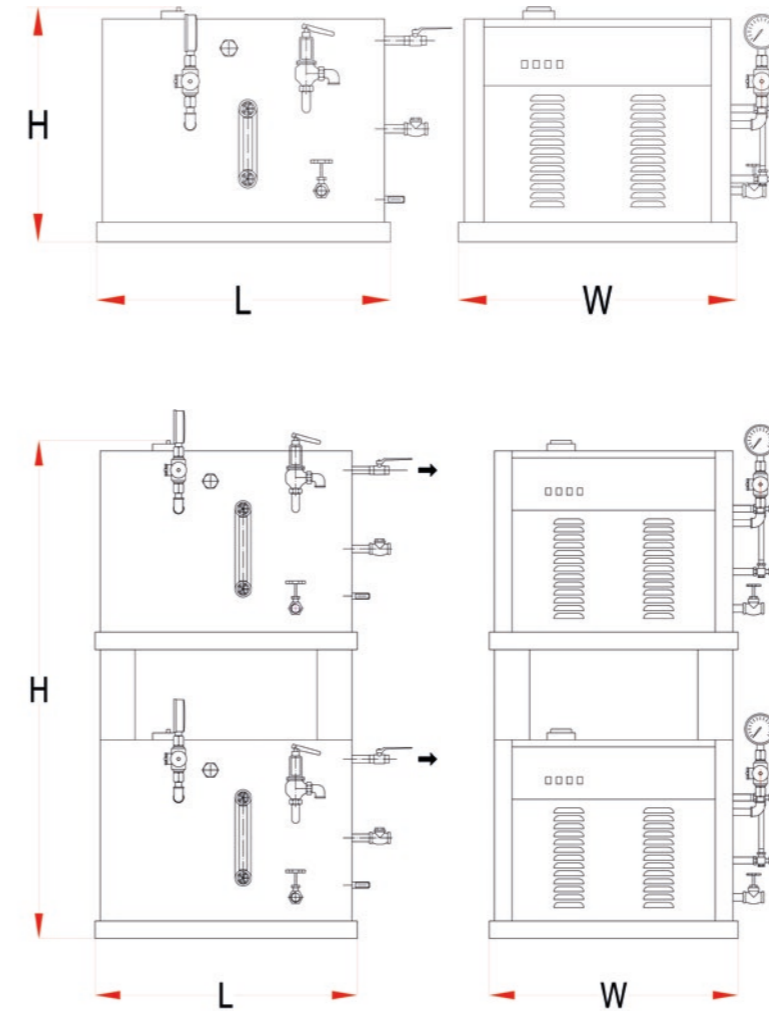
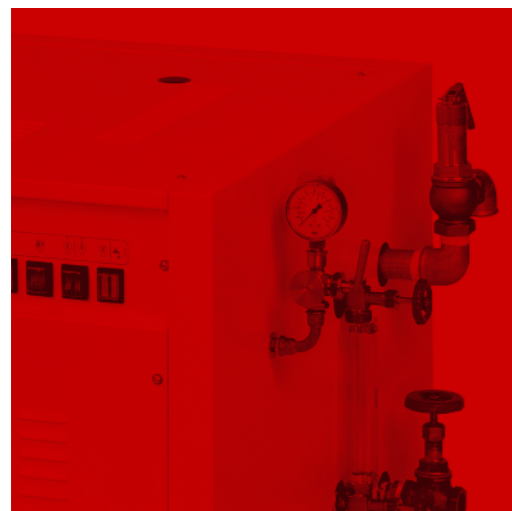

PRODUCT

- Electrical steam generator

TPOLOGY

- Electrical

CAPACITY

- 15 kW - 180 kW

TECHNICAL DATA ELECTRICAL STEAM BOILER

MAXI

TYPE		MAXI 16	MAXI 24	MAXI 60	MAXI 120	MAXI 180
Max power	kW	15	20	60	120	180
Design pressure - version base	bar	4.5	4.5	4.5	4.5	4.5
Design pressure - version 7	bar	N.A.	7.0	7.0	7.0	7.0
Water content	litri	16	24.9	55.0	53.5+53.5	53.5+53.5+53.5
Power supply	Ph/V/Hz	3/220-380/50-60	3/220-380/50	3/220-380/50	3/220-380/50	3/220-380/50
Length	L - mm	1,030	990	900	900	1,550
Width	W - mm	470	680	780	780	1,240
Height	H - mm	670	780	900	1,600	1,900
Empty weight	kg	78	158	191	310	405

STEAM GENERATORS
**GEV
MODEL**

Electric and automatic steam generator, available with power ranging from 100 to 200 kW, made with one or more electrical resistors. Design pressure up to 21 barg.

It's complete with accessories and control panel, frame and external insulation. Automatic regulation with stages. It can be equipped with kit for operation without supervision for 72 hours.

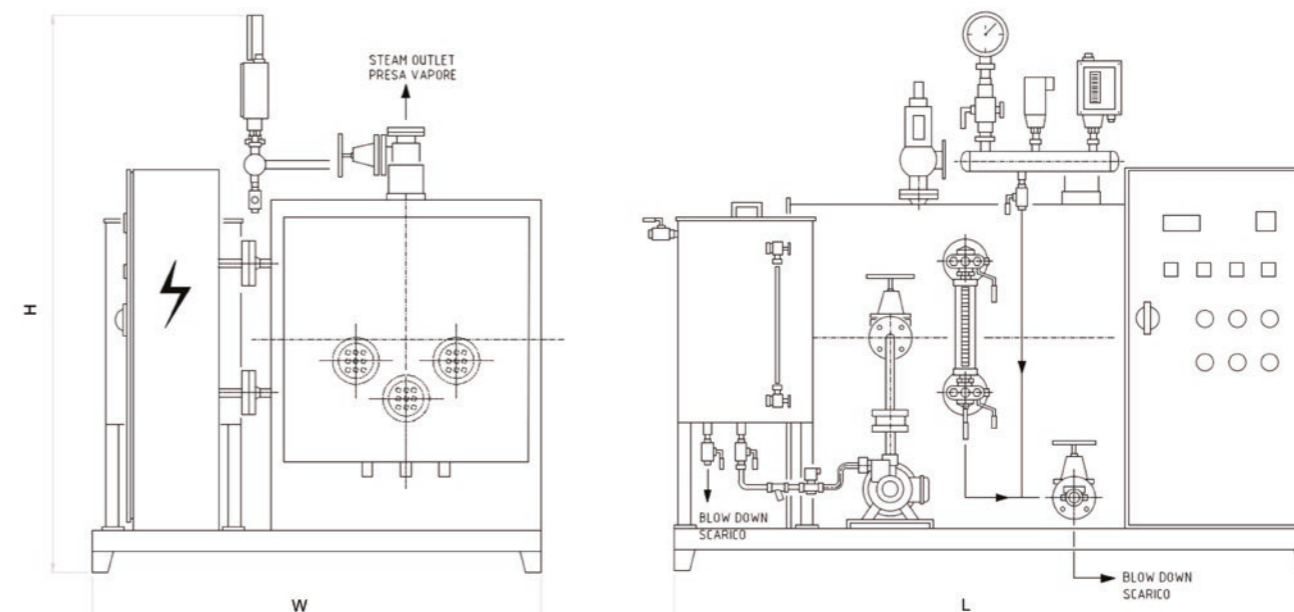
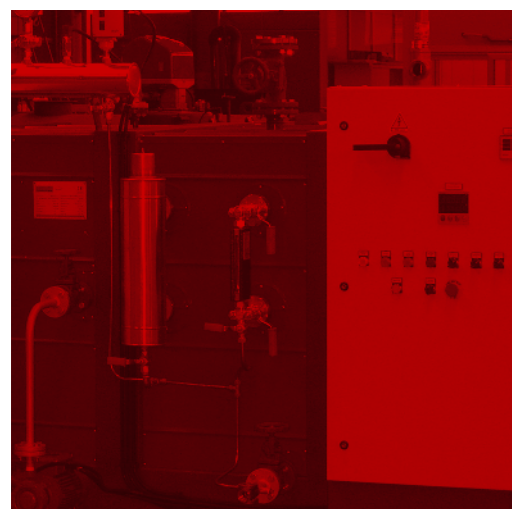

PRODUCT

- Electrical steam generator GEV

TPOLOGY

- Electrical

CAPACITY

- 100 kW - 200 kW

TECHNICAL DATA ELECTRICAL STEAM BOILER

		GEV				
TYPE		GEV 100	GEV 120	GEV 150	GEV 180	GEV 200
Capacity	kcal/h	86,000	103,200	129,000	154,800	172,000
	kW	100	120	150	180	200
Length	mm	2,300	2,300	2,500	2,500	2,800
Width	mm	1,700	1,700	1,700	1,900	1,900
Height	mm	1,800	1,800	1,800	2,000	2,000



THERMAL OIL HEATERS

INDEX

- TH page 38
- GEO page 42

THERMAL OIL HEATERS

We produce direct fired heaters for thermal oil with capacity from 150,000 to 7,000,000 kcal/h and electric heaters for potentials from 50 to 500 kW.

Various options are available such as one or more circulation pumps connected to the heater, burners for various fuels, combustion air preheaters, horizontal and vertical configurations.

All heaters are designed, tested, built on the basis of the latest standards and can be certified according to PED, ASME, naval or other regulations depending on the country of installation.



THERMAL OIL HEATERS

TH MODEL

Thermal oil heaters in horizontal and vertical versions for temperatures up to 320 °C (special versions up to 400°C)

The **TH** heaters have been specially designed for maximum efficiency. On these boilers, you can install any type of market-based burner, thus facilitating assistance in every area at the lowest cost.

They are characterized by:

- Small dimensions
- Quick startup
- Maximum operational safety
- Minimum quantity of refractory material
- Tubular bundle with one or more coiled spiral, balanced and well dimensioned in order to prevent cracking phenomena
- Large volume combustion chamber

Made in both horizontal and vertical versions, to better accommodate customer space requirements.

The version / AR includes a smoke / air exchanger that preheats the combustion air at the expense of the residual heat of the flue gases, improving even further the efficiency of the equipment.

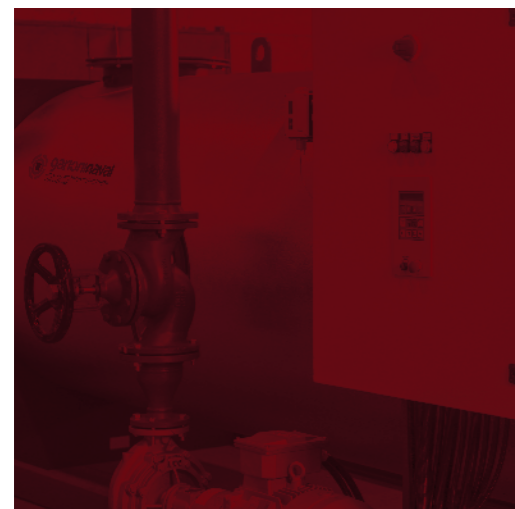

PRODUCT

- Thermal oil heaters, horizontal or vertical

TYOLOGY

- Coil • 3 passes • Horizontal or vertical • For thermal oil

CAPACITY

- 150,000 kcal/h - 7,000,000 kcal/h

TECHNICAL DATA THERMAL OIL HEATERS						TH HORIZONTAL			
TYPE		TH 150	TH 250	TH 350	TH 450	TH 550	TH 800	TH 1000	TH 1250
Capacity	kcal/h	150,000	250,000	350,000	450,000	550,000	800,000	1,000,000	1,250,000
	kW	174	291	407	523	640	930	1,163	1,454
Efficiency (oil 140-180°C)	% ±1	88.0	88.0	89.0	89.0	88.5	89.0	89.5	89.5
Efficiency (oil 240-280°C)	% ±1	86.0	86.0	86.0	86.0	86.0	86.5	86.0	86.5
Oil content	liters	65	92	98	114	147	254	254	453
Oil pressure drop 240-280°C	m oil	28	21	14	23	16	14	22	11
Furnace pressure drop	mm H2O	30	35	40	45	60	80	80	85
Installation length (burner excluded)	L - mm	1,700	2,400	2,400	2,400	2,400	3,350	3,350	3,750
Installation length (burner included)	L1 - mm	2,000	3,000	3,000	3,000	3,000	4,150	4,150	4,600
Installation width (cabinet included)	W - mm	1,300	1,400	1,400	1,400	1,400	1,650	1,650	1,700
Installation height	H - mm	1,600	1,600	1,600	1,600	1,600	1,750	1,750	1,850
Empty weight (burner excluded)	kg	700	1,100	1,100	1,200	1,850	1,950	1,950	2,800

TECHNICAL DATA THERMAL OIL HEATERS						TH HORIZONTAL			
TYPE		TH 1500	TH 2000	TH 2500	TH 3000	TH 4000	TH 5000	TH 6000	TH 7000
Capacity	kcal/h	1,500,000	2,000,000	2,500,000	3,000,000	4,000,000	5,000,000	6,000,000	7,000,000
	kW	1,745	2,326	2,908	3,489	4,652	5,815	6,978	8,141
Efficiency (oil 140-180°C)	% ±1	89.5	89.5	89.5	90.0	89.5	89.5	89.5	89.0
Efficiency (oil 240-280°C)	% ±1	85.0	85.0	85.0	86.0	86.0	86.5	86.0	86.0
Oil content	liters	518	767	1,314	1,520	1,989	2,833	3,127	3,350
Oil pressure drop 240-280°C	m oil	17	19	19	30	28	29	26	30
Furnace pressure drop	mm H2O	90	90	100	100	110	120	120	130
Installation length (burner excluded)	L - mm	4,000	4,300	4,700	5,300	6,200	6,300	7,360	7,850
Installation length (burner included)	L1 - mm	4,800	5,400	5,650	6,400	7,500	8,150	9,250	9,800
Installation width (cabinet included)	W - mm	1,700	2,200	2,400	2,400	2,350	2,400	2,770	2,750
Installation height	H - mm	2,000	2,200	2,650	2,400	2,650	2,910	2,950	3,200
Empty weight (burner excluded)	kg	3,200	5,000	6,500	7,100	8,500	12,600	13,500	14,200

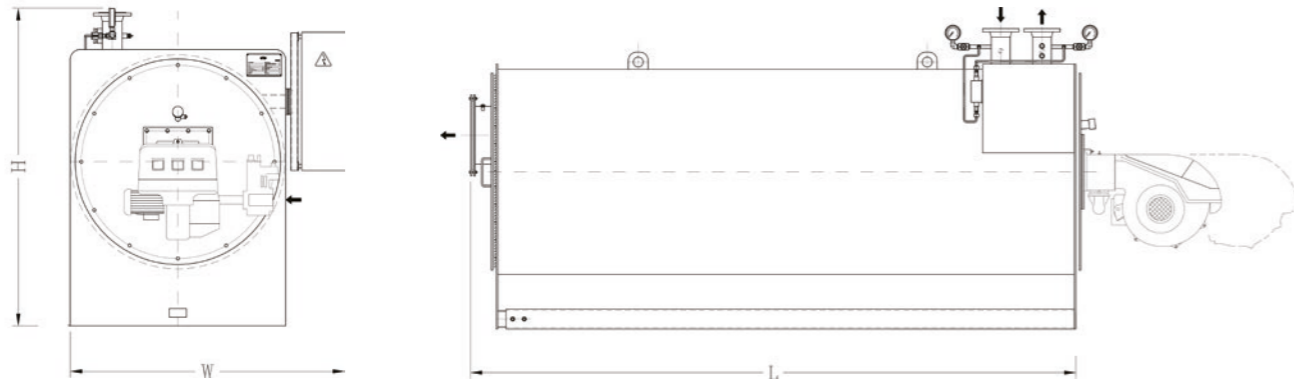

TECHNICAL DATA THERMAL OIL HEATERS		TH VERTICAL							
TYPE		TH/V 150	TH/V 250	TH/V 350	TH/V 450	TH/V 550	TH/V 800	TH/V 1000	TH/V 1250
Capacity	kcal/h	150,000	250,000	350,000	450,000	550,000	800,000	1,000,000	1,250,000
	kW	174	291	407	523	640	930	1,163	1,454
Efficiency (oil 140-180°C)	% ±1	88.0	88.0	89.0	89.0	88.5	89.0	89.5	89.5
Efficiency (oil 240-280°C)	% ±1	86.0	86.0	86.0	86.0	86.0	86.5	86.0	86.5
Oil content	liters	65	92	98	114	147	254	254	453
Oil pressure drop 240-280°C	m oil	28	21	14	23	16	14	22	11
Furnace pressure drop	mm H2O	30	35	40	45	60	80	80	85
Installation length (burner excluded)	H - mm	1,700	2,400	2,400	2,400	2,400	3,350	3,350	3,750
Installation length (burner included)	H1 - mm	2,000	3,000	3,000	3,000	3,000	4,150	4,150	4,600
Installation width (cabinet included)	W - mm	1,300	1,400	1,400	1,400	1,400	1,650	1,650	1,700
Installation height	L - mm	1,200	1,300	1,300	1,300	1,300	1,550	1,550	1,600
Empty weight (burner excluded)	kg	700	1,100	1,100	1,200	1,850	1,950	1,950	2,800

TECHNICAL DATA THERMAL OIL HEATERS		TH VERTICAL							
TYPE		TH/V 1500	TH/V 2000	TH/V 2500	TH/V 3000	TH/V 4000	TH/V 5000	TH/V 6000	TH/V 7000
Capacity	kcal/h	1,500,000	2,000,000	2,500,000	3,000,000	4,000,000	5,000,000	6,000,000	7,000,000
	kW	1,745	2,326	2,908	3,489	4,652	5,815	6,978	8,141
Efficiency (oil 140-180°C)	% ±1	89.5	89.5	89.5	90.0	89.5	89.5	89.5	89.0
Efficiency (oil 240-280°C)	% ±1	85.0	85.0	85.0	86.0	86.0	86.5	86.0	86.0
Oil content	liters	518	767	1,314	1,520	1,989	2,833	3,127	3,350
Oil pressure drop 240-280°C	m oil	17	19	19	30	28	29	26	30
Furnace pressure drop	mm H2O	90	90	100	100	110	120	120	130
Installation length (burner excluded)	H - mm	4,000	4,300	4,700	5,300	6,200	6,300	7,360	7,850
Installation length (burner included)	H1 - mm	4,800	5,400	5,650	6,400	7,500	8,150	9,250	9,800
Installation width (cabinet included)	W - mm	1,700	2,200	2,400	2,400	2,350	2,400	2,770	2,750
Installation height	L - mm	1,600	2,100	2,300	2,300	2,250	2,300	2,670	2,650
Empty weight (burner excluded)	kg	3,200	5,000	6,500	7,100	8,500	12,600	13,500	14,200



THERMAL OIL HEATERS

GEO MODEL

Electric and automatic thermal oil heater, available with variable power from 10 to 500 kW, made with one or more electrical resistors.

Design temperature up to 320 °C and pressure up to 10 bar. Complete with accessories and control panel, base and external insulation. Automatic regulation with stages.

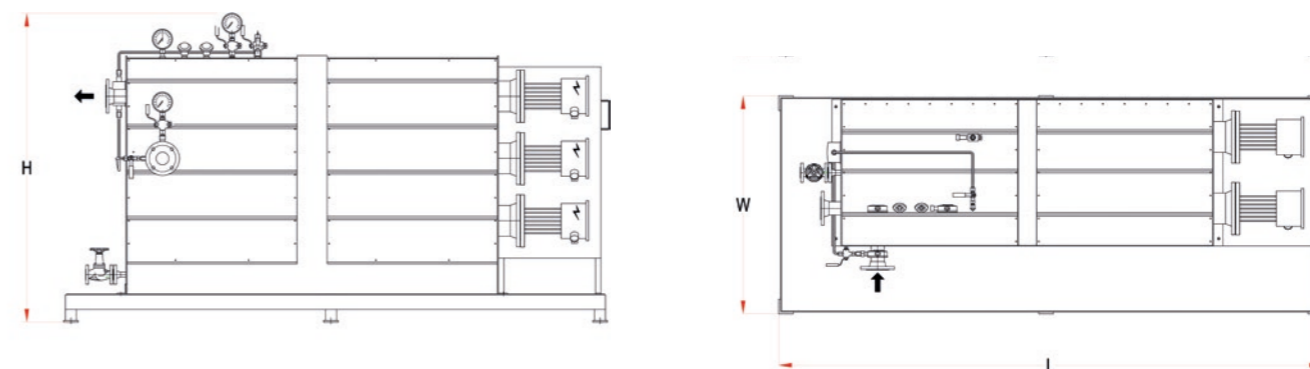

PRODUCT

- Electrical heater for thermal oil

TYOLOGY

- Electrical thermal oil heater

CAPACITY

- 10 kW - 500 kW

TECHNICAL DATA ELECTRICAL OIL HEATER

GEO

TYPE		GEO 10	GEO 30	GEO 50	GEO 80	GEO 100	GEO 120
		Capacity	kcal/h	8,600	25,800	43,000	68,800
	kW	10	30	50	80	100	120
Length	mm	2,300	2,500	2,600	2,600	2,900	2,900
Width	mm	850	850	900	1,100	1,300	1,300
Height	mm	1,300	1,400	1,500	1,600	1,950	1,950

TECHNICAL DATA ELECTRICAL OIL HEATER

GEO

TYPE		GEO 160	GEO 200	GEO 250	GEO 300	GEO 500
		Capacity	kcal/h	137,600	172,000	215,000
	kW	160	200	250	300	500
Length	mm	3,200	3,500	3,800	3,800	4,000
Width	mm	1,400	1,600	1,800	1,800	2,000
Height	mm	2,100	2,200	2,300	2,300	2,400



HOT WATER HEATERS

INDEX

- **NPR** page 46
- **NPR - 3S** page 50
- **GMT/AC** page 54
- **GPT/AC** page 56

HOT WATER HEATERS

We design and manufacture direct fired heaters for hot water with capacity from 50 to 20,000 kW.

Various options are available such as one or more circulation pumps connected to the heater, burners for various fuels, economizers, combustion air preheaters, horizontal and vertical configurations. All heaters are designed, tested, built on the basis of the latest standards and can be certified according to PED, ASME, naval or other regulations depending on the country of installation.



HOT WATER HEATERS
**NPR
MODEL**

Pressurized steel boiler for hot water production.
It can be equipped with a normal market burner and is suitable for liquid or gaseous fuels. Two-position adjustment or, on request, modulating. Water efficiency of over 90%.

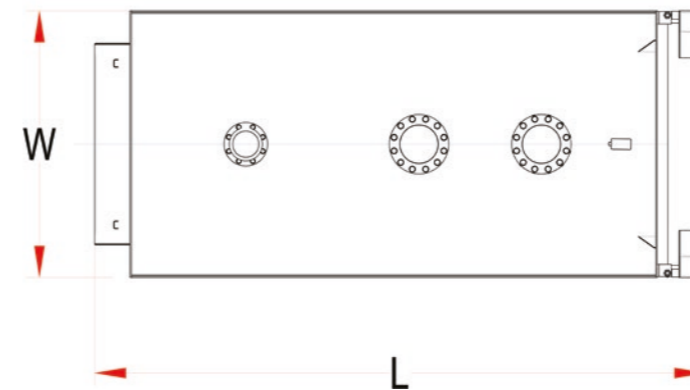

PRODUCT

- Pressurized heater for hot water

TYOLOGY

- Fire tube • 3 passes • Wet back • Flame inversion • Horizontal

CAPACITY

- 64 kW - 7,000 kW

TECHNICAL DATA HOT WATER HEATER

NPR

TYPE		NPR										
		NPR 64	NPR 76	NPR 93	NPR 105	NPR 116	NPR 140	NPR 163	NPR 186	NPR 233	NPR 291	NPR 340
Max net output	kW	64	76	93	105	116	140	163	186	233	291	340
Max furnace output	kW	71	84	102	115	128	155	180	206	258	322	371
Water content	liters	86	86	86	126	126	126	151	151	203	247	298
Design pressure	bar	6	6	6	6	6	6	6	6	6	6	6
Efficiency	%	90.1%	90.5%	91.2%	91.3%	90.6%	90.3%	90.6%	90.3%	90.3%	90.4%	91.6%
Furnace pressure drop	mm H2O	1.5	1.8	2.5	3	3	4	8	14	18	22	34
Length (burner excluded)	L - mm	990	990	990	1,205	1,205	1,205	1,385	1,385	1,437	1,687	1,541
Width	W - mm	690	690	690	760	760	760	760	760	860	860	890
Height	H - mm	722	722	722	812	812	812	812	812	937	937	1,310
Empty weight	kg	212	212	212	309	309	309	349	349	485	555	629



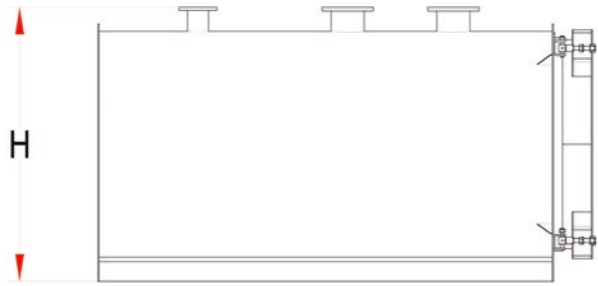

TECHNICAL DATA HOT WATER HEATER		NPR										
TYPE		NPR 420	NPR 510	NPR 630	NPR 760	NPR 870	NPR 970	NPR 1100	NPR 1320	NPR 1570	NPR 1850	NPR 2200
Max net output	kW	420	510	630	760	870	970	1,100	1,320	1,570	1,850	2,200
Max furnace output	kW	459	557	688	830	950	1,060	1,200	1,442	1,715	2,020	2,400
Water content	liters	398	462	565	671	753	836	1,040	1,242	1,418	1,617	2,086
Design pressure	bar	6	6	6	6	6	6	6	6	6	6	6
Efficiency	%	91.5%	91.6%	91.6%	91.6%	91.6%	91.5%	91.7%	91.5%	91.5%	91.6%	91.7%
Furnace pressure drop	mm H2O	29	43	55	51	57	49	52	67	60	73	65
Length (burner excluded)	L - mm	1,606	1,801	2,113	1,989	2,184	2,379	2,346	2,686	2,781	3,151	3,225
Width	W - mm	890	890	890	1,122	1,122	1,122	1,352	1,352	1,462	1,462	1,622
Height	H - mm	1,485	1,485	1,485	1,540	1,540	1,540	1,540	1,540	1,650	1,650	1,810
Empty weight	kg	796	919	1,049	1,341	1,447	1,553	1,821	2,030	2,780	3,280	4,145

TECHNICAL DATA HOT WATER HEATER		NPR									
TYPE		NPR 2650	NPR 3000	NPR 3500	NPR 4000	NPR 4500	NPR 5000	NPR 5500	NPR 6000	NPR 6500	NPR 7000
Max net output	kW	2,650	3,000	3,500	4,000	4,500	5,000	5,500	6,000	6,500	7,000
Max furnace output	kW	2,890	3,280	3,825	4,371	4,838	5,422	5,914	6,507	6,990	7,591
Water content	liters	2,324	2,667	4,142	4,455	6,012	6,012	7,058	7,058	7,909	7,909
Design pressure	bar	6	6	6	6	6	6	6	6	6	6
Efficiency	%	91.7%	91.5%	91.5%	91.5%	93.0%	92.2%	93.0%	92.2%	93.0%	92.2%
Furnace pressure drop	mm H2O	76	60	74	80	8	110	100	120	105	120
Length (burner excluded)	L - mm	3,545	3,835	3,879	4,279	4,282	4,282	4,872	4,872	5,484	5,484
Width	W - mm	1,622	1,720	1,970	1,970	2,088	2,088	2,214	2,214	2,380	2,380
Height	H - mm	1,810	1,990	2,271	2,271	2,533	2,533	2,653	2,653	2,860	2,860
Empty weight	kg	4,465	5,110	6,700	7,500	4,682	4,682	4,872	4,872	5,484	5,484

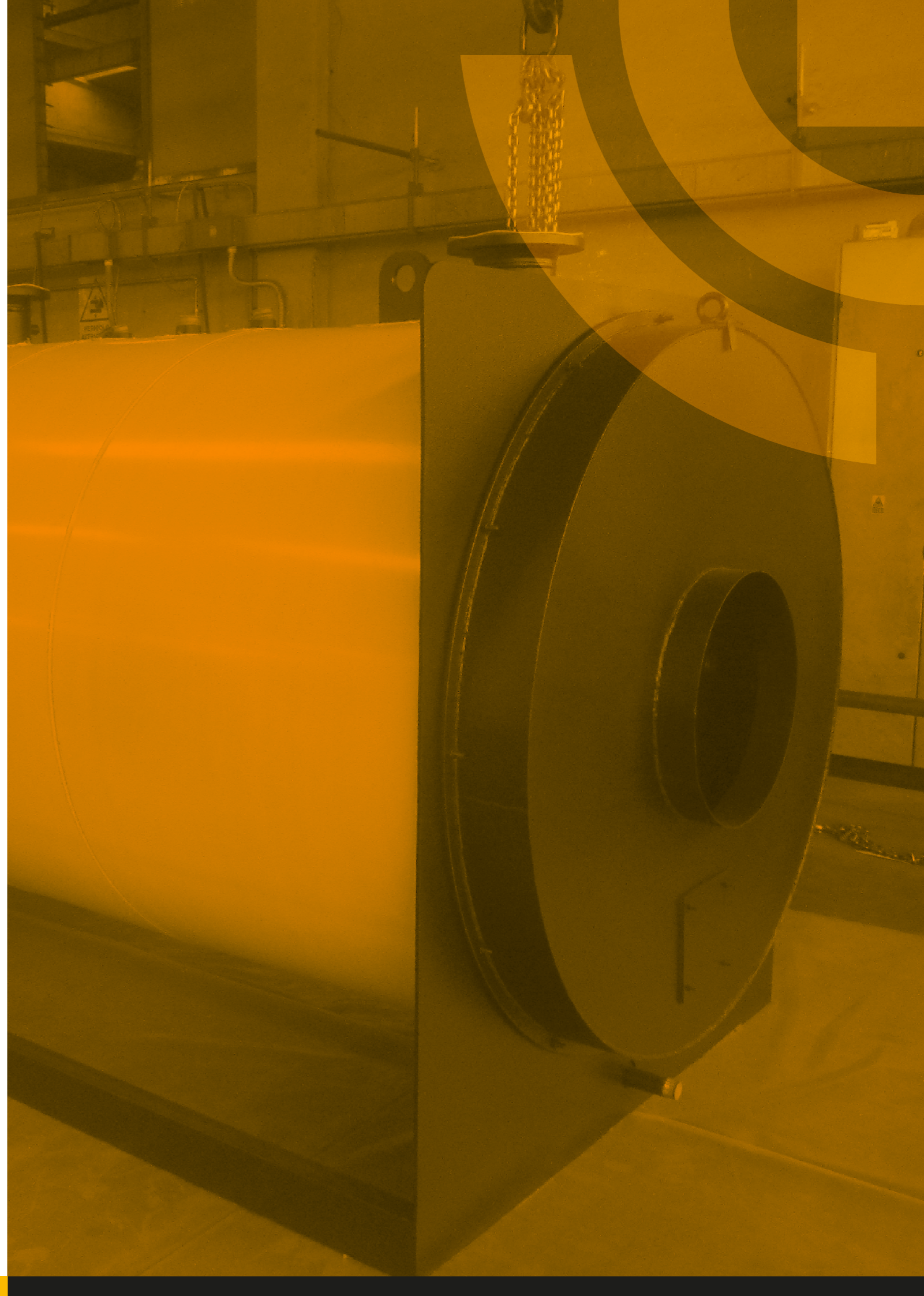

HOT WATER HEATERS
**NPR - 3S
MODEL**

Pressurized steel boiler for hot water production. It can be equipped with a normal market burner and is suitable for liquid or gaseous fuels. Two-position adjustment or, on request, modulating.

The **NPR 3S** boiler is designed to guarantee a very high efficiency, over 94% for power up to 250 kW and more than 95% for models with power of 300 kW and above.

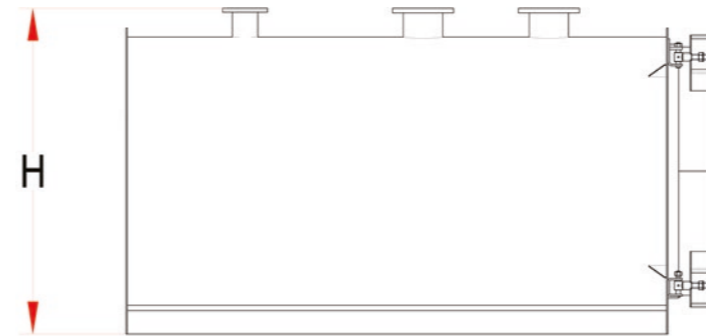
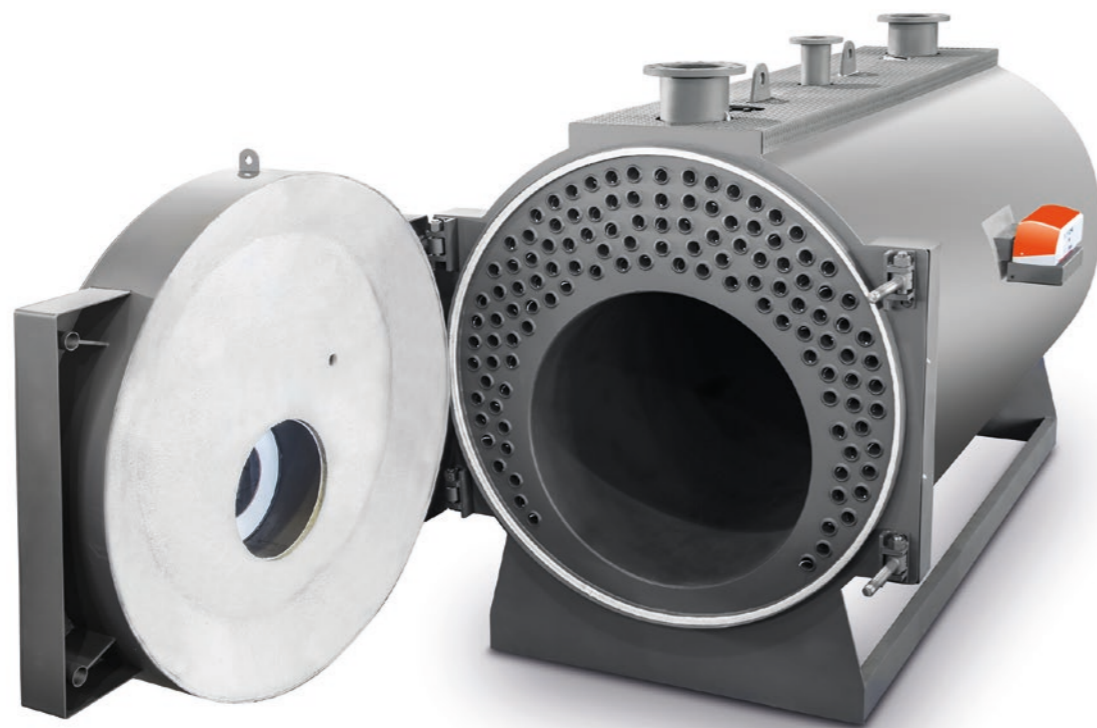

PRODUCT

- Pressurized heater for hot water with high efficiency

TYOLOGY

- Fire tube • 3 passes • Wet back • Flame inversion • Horizontal

CAPACITY

- 80 kW - 6,100 kW

TECHNICAL DATA HOT WATER HEATER

NPR - 3S

TYPE		NPR 80 3S	NPR 120 3S	NPR 160 3S	NPR 200 3S	NPR 250 3S	NPR 300 3S	NPR 370 3S
Max net output	kW	80	120	160	200	250	300	370
Max furnace output	kW	85.2	127.4	169.4	211.3	263.6	315.8	388.7
Water content	liters	86	126	151	203	247	298	398
Design pressure	bar	5	5	5	5	5	6	6
Efficiency	%	93.9%	94.2%	94.5%	94.7%	94.8%	95.0%	95.2%
Furnace pressure drop	mm H2O	6.8	10.8	15.8	19.7	23.6	28.4	32.2
Length (burner excluded)	L - mm	995	1,210	1,390	1,442	1,692	1,541	1,606
Width	W - mm	690	760	760	860	860	860	890
Height	H - mm	912	1,002	1,002	1,127	1,127	1,372	1,542
Empty weight	kg	221	325	366	505	583	665	845

TECHNICAL DATA HOT WATER HEATER

NPR - 3S

TYPE		NPR 450 3S	NPR 560 3S	NPR 680 3S	NPR 780 3S	NPR 870 3S	NPR 1000 3S	NPR 1180 3S
Max net output	kW	450	560	680	780	870	1,000	1,180
Max furnace output	kW	472.4	587.9	713.9	818.9	913.4	1,049.8	1,238.8
Water content	liters	462	565	617	753	836	1,040	1,242
Design pressure	bar	6	6	6	6	6	6	6
Efficiency	%	95.3%	95.3%	95.3%	95.2%	95.2%	95.3%	95.3%
Furnace pressure drop	mm H2O	35.8	42.1	49.4	55	58.6	69.9	68.6
Length (burner excluded)	L - mm	1,801	2,113	1,989	2,184	1,989	2,346	2,686
Width	W - mm	890	890	1,122	1,122	1,122	1,352	1,352
Height	H - mm	1,542	1,542	1,622	1,622	1,622	1,622	1,622
Empty weight	kg	986	1,119	1,435	1,557	1,656	1,970	2,175

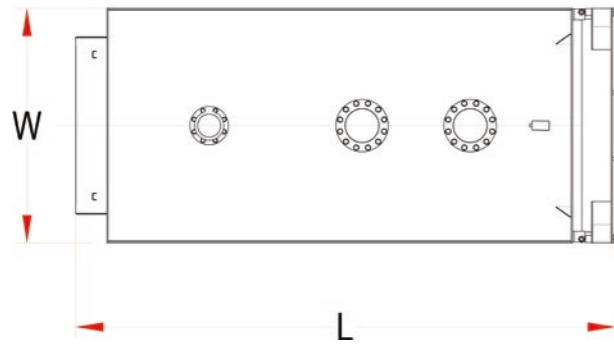

TECHNICAL DATA HOT WATER HEATER		NPR - 3S						
TYPE		NPR 1400 3S	NPR 1650 3S	NPR 2000 3S	NPR 2350 3S	NPR 2700 3S	NPR 3100 3S	NPR 3500 3S
Max net output	kW	1,400	1,650	2,000	2,350	2,700	3,100	3,500
Max furnace output	kW	1,469.8	1,732.3	2,099.7	2,467.1	2,834.6	3,254.5	3,674.5
Water content	liters	1,418	1,617	2,086	2,324	2,667	4,142	4,455
Design pressure	bar	6	6	6	6	6	6	6
Efficiency	%	95.3%	95.2%	95.3%	95.3%	95.3%	95.3%	95.3%
Furnace pressure drop	mm H2O	74.9	80.9	72	76.9	81	769	89.5
Length (burner excluded)	L - mm	2,781	3,151	3,225	3,545	3,835	3,879	4,279
Width	W - mm	1,462	1,462	1,622	1,622	1,720	1,970	1,970
Height	H - mm	1,732	1,732	1,892	1,892	2,020	2,280	2,280
Empty weight	kg	2,975	3,465	4,390	4,700	5,370	6,990	7,790

TECHNICAL DATA HOT WATER HEATER		NPR - 3S					
TYPE		NPR 3900 3S	NPR 4400 3S	NPR 4800 3S	NPR 5200 3S	NPR 5700 3S	NPR 6100 3S
Max net output	kW	3,900	4,400	4,800	5,200	5,700	6,100
Max furnace output	kW	4,094.4	4,619.3	5,039.3	5,459.2	5,984.1	6,404.1
Water content	liters	6012	6012	7058	7058	7909	7909
Design pressure	bar	6	6	6	6	6	6
Efficiency	%	95.3%	95.3%	95.3%	95.3%	95.3%	95.3%
Furnace pressure drop	mm H2O	79	58.6	92.2	105.4	90.5	100.7
Length (burner excluded)	L - mm	4,738	4,738	4,928	4,928	5,484	5,484
Width	W - mm	2,088	2,088	2,214	2,214	2,380	2,380
Height	H - mm	2,533	2,533	2,653	2,653	2,860	2,860
Empty weight	kg	8,630	8,630	9,675	9,675	13,060	13,060



HOT WATER HEATERS
**GMT/AC
MODEL**

Water heaters in horizontal and vertical versions for temperatures up to 110°C and pressure up to 10 barg. Upon request versions for higher pressure may be realized.

The **GMT/AC** and **GMT/AC/V** heaters have been specially designed for maximum efficiency. On these boilers, it's possible to install any type of market-based burner, thus facilitating assistance in every area at the lowest cost.

They are characterized by:

- Small dimensions
- Quick startup
- Maximum operational safety
- Minimum quantity of refractory material
- Tubular bundle with one or more coiled spiral, balanced and well dimensioned in order to prevent cracking phenomena
- Large volume combustion chamber
- Limited water content

Made in both horizontal and vertical versions, to better accommodate customer space requirements.

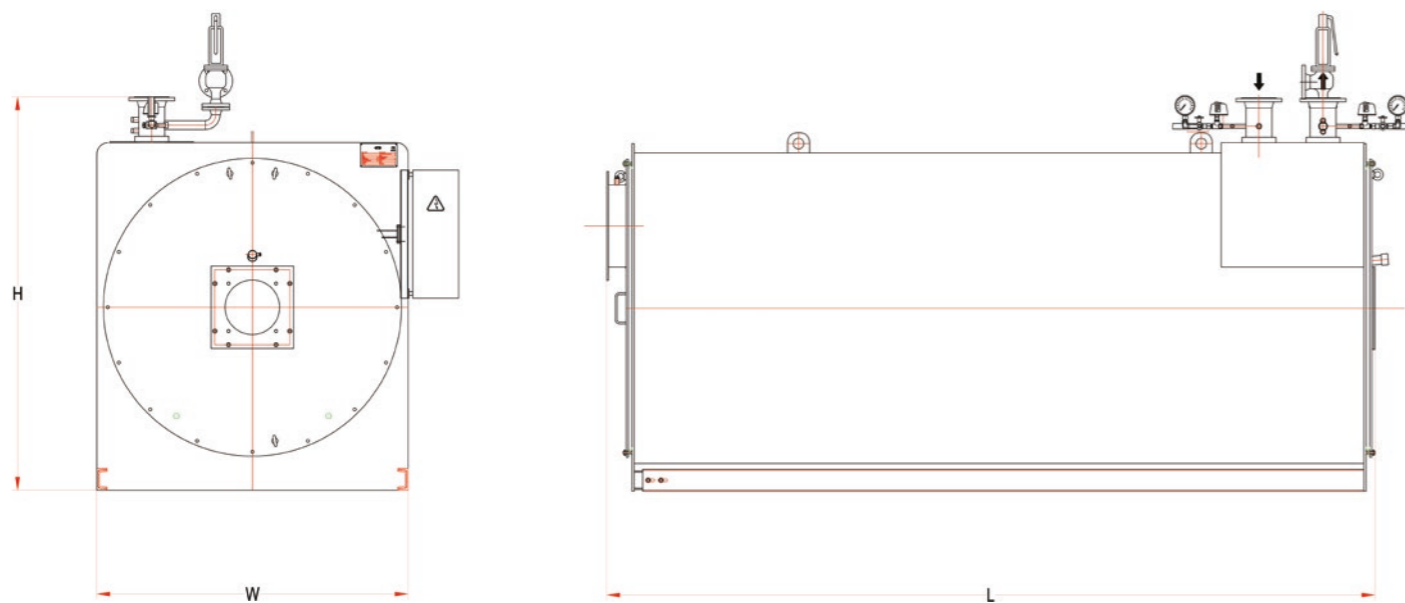
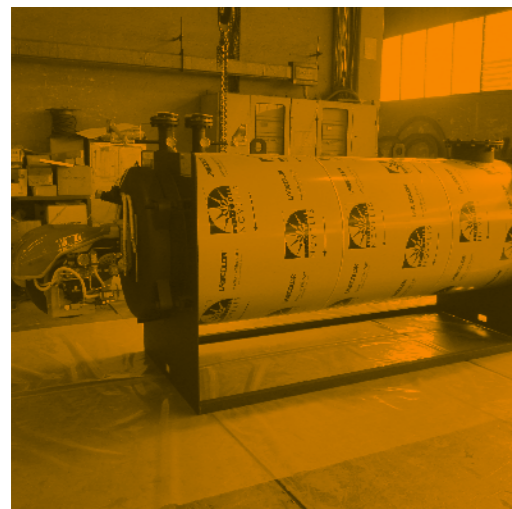

PRODUCT

- Heater for hot water, coil type

TPOLOGY

- Coil • 3 passes • Horizontal or vertical • For hot water

CAPACITY

- 150,000 kcal/h – 7,000,000 kcal/h

TECHNICAL DATA HOT WATER HEATERS					GMT/AC				
TYPE		GMT/AC 150	GMT/AC 250	GMT/AC 350	GMT/AC 450	GMT/AC 550	GMT/AC 800	GMT/AC 1000	GMT/AC 1250
Capacity	kcal/h	150,000	250,000	350,000	450,000	550,000	800,000	1,000,000	1,250,000
	kW	174	291	407	523	640	930	1,163	1,454
	Btu/h	595,223	992,039	1,388,855	1,785,670	2,182,486	3,174,525	3,968,156	4,960,195
	HP	234	390	546	702	858	1,248	1,560	1,949
Water inlet temperature	°C	60	60	60	60	60	60	60	60
Water outlet temperature	°C	90	90	90	90	90	90	90	90
Efficiency (oil 60-90°C)	% ±1	92.5	92.5	92.5	92.5	92.5	92.5	92.5	92.5
Water content	liters	65	92	98	114	147	254	254	453
Water pressure drop 60-90°C	mm H2O	30	35	40	45	60	80	80	85
Installation length (burner excluded)	mm	1,700	2,400	2,400	2,400	2,400	3,350	3,350	3,750
Installation length (burner included)	mm	2,000	3,000	3,000	3,000	3,000	4,150	4,150	4,600
Installation width (cabinet included)	mm	1,300	1,400	1,400	1,400	1,400	1,650	1,650	1,700
Installation height	mm	1,600	1,600	1,600	1,600	1,600	1,750	1,750	1,850
Empty weight (burner excluded)	kg	700	1,100	1,100	1,200	1,850	1,950	1,950	2,800

TECHNICAL DATA HOT WATER HEATERS					GMT/AC				
TYPE		GMT/AC 1500	GMT/AC 2000	GMT/AC 2500	GMT/AC 3000	GMT/AC 4000	GMT/AC 5000	GMT/AC 6000	GMT/AC 7000
Capacity	kcal/h	1,500,000	2,000,000	2,500,000	3,000,000	4,000,000	5,000,000	6,000,000	7,000,000
	kW	1,745	2,326	2,908	3,489	4,652	5,815	6,978	8,141
	Btu/h	5,952,234	7,936,312	9,920,390	11,904,468	15,872,624	19,840,780	23,808,936	27,777,092
	HP	2,339	3,119	3,899	4,679	6,238	7,798	9,357	10,917
Water inlet temperature	°C	60	60	60	60	60	60	60	60
Water outlet temperature	°C	90	90	90	90	90	90	90	90
Efficiency (oil 60-90°C)	% ±1	92.5	92.5	92.5	92.8	92.5	92.5	92.5	92.0
Water content	liters	518	767	1,314	1,520	1,989	2,833	3,127	3,350
Water pressure drop 60-90°C	mm H2O	90	90	100	100	110	120	120	150
Installation length (burner excluded)	mm	4,000	4,300	4,700	5,300	6,200	6,300	7,360	7,850
Installation length (burner included)	mm	4,800	5,400	5,650	6,400	7,500	8,150	9,250	9,800
Installation width (cabinet included)	mm	1,700	2,200	2,400	2,400	2,350	2,400	2,770	2,750
Installation height	mm	2,000	2,200	2,650	2,400	2,650	2,910	2,950	3,200
Empty weight (burner excluded)	kg	3,200	5,000	6,500	7,100	8,500	12,600	13,500	14,200

HOT WATER HEATERS
**GPT/AC
MODEL**

The **GPT/AS** heater, 3-passes type, is the most technologically advanced there is on the market today. It has been thoroughly engineered to ensure maximum efficiency (up to 95% efficiency using GN-ECO economizers) and minimum NOx emissions, according with the environmental regulations.

The high-volume and high-performance GPT/AS heater is indicated for industries where flexibility of operation, safety and continuity are required. It represents a solution for all installations where the absolute guarantee of the components is required, an impeccable and cured construction, and a sizing that takes into account harsh operating conditions.

- 3-Passes water heater with wet back
- High performance and low NOx content
- Production from 3,000 to 20,000 kW
- Pressure up to 16 barg
- Suitable for liquid or gaseous fuels
- Two-position or modulating versions both on fuel and on feed water

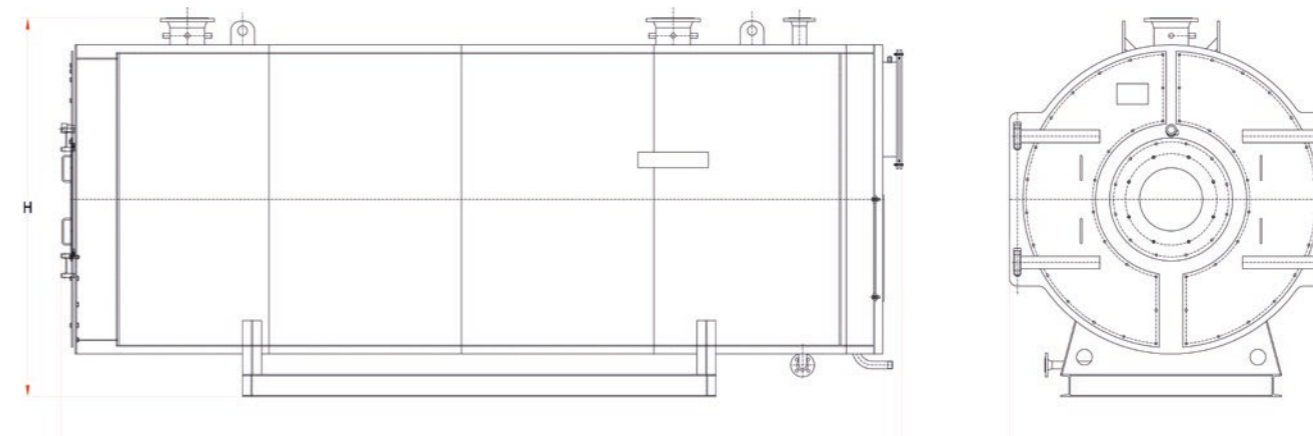

PRODUCT

- Water heater, fire tube, 3 passes, up to 16 barg

TYPOLGY

- Fire tube • 3 passes • Wet back • Through furnace • Horizontal

CAPACITY

- 3,000 kW – 20,000 kW

TECHNICAL DATA THREE PASSES SMOKE HOT WATER BOILER

GPT/AC

TYPE		GPT/AC									
		GPT/AC 2000	GPT/AC 3000	GPT/AC 4000	GPT/AC 5000	GPT/AC 6000	GPT/AC 8000	GPT/AC 10000	GPT/AC 12000	GPT/AC 14000	
Net power	kW	2,000	3,000	4,000	5,000	6,000	8,000	10,000	12,000	14,000	
Water content	liters	4,279	5,200	6,325	6,760	10,600	11,880	15,500	17,500	20,500	
Heating surface	m2	75	82	98	128	174	212	268	302	342	
Water pressure drop	mbar	100	100	100	110	100	110	170	250	260	
Furnace pressure drop	mbar	9.0	10.0	10.5	11.0	11.0	13.0	13.5	14.0	17.0	
Empty weight 6bar	kg	322	292	323	371	430	526	617	640	764	
Stack connection diam.	mm	550	550	600	700	700	800	900	900	1,000	
Water in/out connect.	DN	DN200	DN200	DN200	DN200	DN250	DN250	DN250	DN300	DN300	
Length (body only)	mm	3,996	4,910	5,152	5,422	6,132	6,432	6,452	6,732	7,332	
Width (body only)	mm	1,950	1,950	2,020	2,100	2,350	2,480	2,800	2,900	3,000	
Height (body only)	mm	2,370	2,370	2,370	2,450	2,700	2,900	3,300	3,400	3,500	

Data for the sizes bigger than 14,000 supplied on request



SUPERHEATED WATER HEATERS

INDEX

- GMT/AS page 60
- GPT/AS page 62

SUPERHEATED WATER HEATERS

We design and produce direct fired heaters for superheated water with capacity from 150 to 20,000 kW.

Various options are available such as one or more circulation pumps connected to the heater, burners for various fuels, economizers, combustion air preheaters, horizontal and vertical configurations. All heaters are designed, tested, built on the basis of the latest standards and can be certified according to PED, ASME, naval or other regulations depending on the country of installation.



SUPERHEATED WATER HEATERS
GMT/AS MODEL

Water heaters in horizontal and vertical versions for temperatures up to 180°C and pressure up to 10 barg. Upon request versions for higher temperature and pressure may be realized.

The **GMT/AS** and **GMT/AS/V** heaters have been specially designed for maximum efficiency. On these boilers, you can install any type of market-based burner, thus facilitating assistance in every area at the lowest cost.

They are characterized by:

- Small dimensions
- Quick startup
- Maximum operational safety
- Minimum quantity of refractory material
- Tubular bundle with one or more coiled spiral, balanced and well dimensioned in order to prevent cracking phenomena
- Large volume combustion chamber
- Limited water content

Made in both horizontal and vertical versions, to better accommodate customer space requirements.

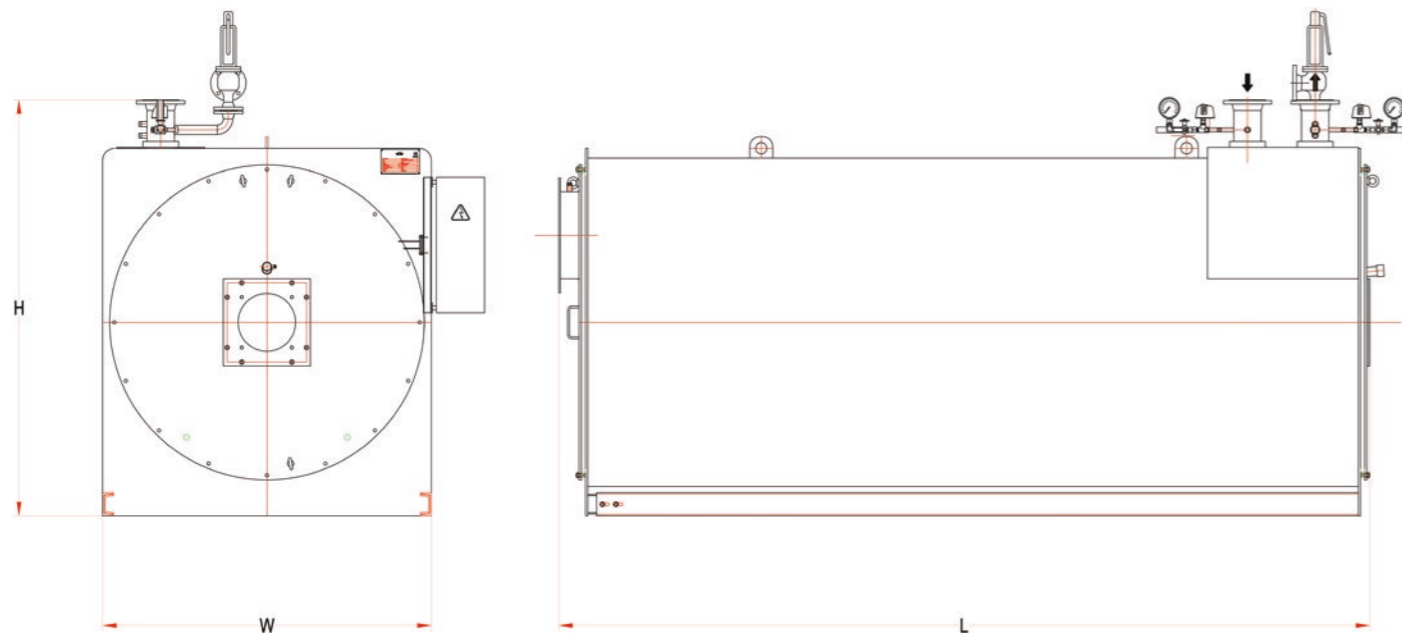
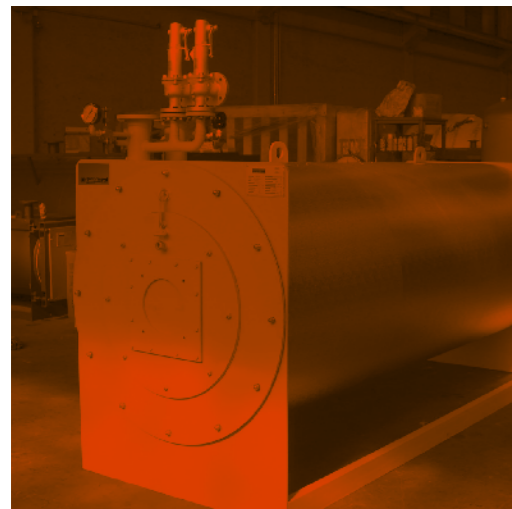

PRODUCT

- Heater for superheated water, coil type

TYOLOGY

- Coil • 3 passes • Horizontal or vertical • For superheated water

CAPACITY

- 150,000 kcal/h – 7,000,000 kcal/h

TECHNICAL DATA SUPERHEATED WATER HEATERS		GMT/AS							
TYPE		GMT/AS 150	GMT/AS 250	GMT/AS 350	GMT/AS 450	GMT/AS 550	GMT/AS 800	GMT/AS 1000	GMT/AS 1250
Capacity	kcal/h	150,000	250,000	350,000	450,000	550,000	800,000	1,000,000	1,250,000
	kW	174	291	407	523	640	930	1,163	1,454
	Btu/h	595,223	992,039	1,388,855	1,785,670	2,182,486	3,174,525	3,968,156	4,960,195
	HP	234	390	546	702	858	1,248	1,560	1,949
Water inlet temperature	°C	120	120	120	120	120	120	120	120
Water outlet temperature	°C	150	150	150	150	150	150	150	150
Efficiency (oil 120-150°C)	% ±1	89.0	89.0	89.0	89.0	89.0	89.0	89.0	89.0
Water content	liters	65	92	98	114	147	254	254	453
Water pressure drop 120-150°C	mm H2O	30	35	40	45	60	80	80	85
Installation length (burner excluded)	mm	1,700	2,400	2,400	2,400	2,400	3,350	3,350	3,750
Installation length (burner included)	mm	2,000	3,000	3,000	3,000	3,000	4,150	4,150	4,600
Installation width (cabinet included)	mm	1,300	1,400	1,400	1,400	1,400	1,650	1,650	1,700
Installation height	mm	1,600	1,600	1,600	1,600	1,600	1,750	1,750	1,850
Empty weight (burner excluded)	kg	700	1,100	1,100	1,200	1,850	1,950	1,950	2,800

TECHNICAL DATA SUPERHEATED WATER HEATERS		GMT/AS							
TYPE		GMT/AS 1500	GMT/AS 2000	GMT/AS 2500	GMT/AS 3000	GMT/AS 4000	GMT/AS 5000	GMT/AS 6000	GMT/AS 7000
Capacity	kcal/h	1,500,000	2,000,000	2,500,000	3,000,000	4,000,000	5,000,000	6,000,000	7,000,000
	kW	1,745	2,326	2,908	3,489	4,652	5,815	6,978	8,141
	Btu/h	5,952,234	7,936,312	9,920,390	11,904,468	15,872,624	19,840,780	23,808,936	27,777,092
	HP	2,339	3,119	3,899	4,679	6,238	7,798	9,357	10,917
Water inlet temperature	°C	120	120	120	120	120	120	120	120
Water outlet temperature	°C	150	150	150	150	150	150	150	150
Efficiency (oil 120-150°C)	% ±1	89.0	89.0	89.0	90.0	89.0	89.0	89.0	89.0
Water content	liters	518	767	1,314	1,520	1,989	2,833	3,127	3,350
Water pressure drop 120-150°C	mm H2O	90	90	100	100	110	120	120	150
Installation length (burner excluded)	mm	4,000	4,300	4,700	5,300	6,200	6,300	7,360	7,850
Installation length (burner included)	mm	4,800	5,400	5,650	6,400	7,500	8,150	9,250	9,800
Installation width (cabinet included)	mm	1,700	2,200	2,400	2,400	2,350	2,400	2,770	2,750
Installation height	mm	2,000	2,200	2,650	2,400	2,650	2,910	2,950	3,200
Empty weight (burner excluded)	kg	3,200	5,000	6,500	7,100	8,500	12,600	13,500	14,200

SUPERHEATED WATER HEATERS
GPT/AS MODEL

This model, 3-passes type, is the most technologically advanced there is on the market today. It has been thoroughly engineered to ensure maximum efficiency (up to 95% efficiency using GN-ECO economizers) and minimum NOx emissions, according to the environmental regulations.

The high-volume and high-performance **GPT/AS** heater is indicated for applications where flexibility of operation, safety and continuity are required. It represents a solution for all installations where the absolute guarantee of the components is required, an impeccable and cured construction, and a sizing that takes into account harsh operating conditions.

- 3-Passes water heater with wet back
- High performance and low NOx content
- Production from 3,000 to 20,000 kW
- Pressure up to 16 barg
- Suitable for liquid or gaseous fuels
- Two-position or modulating versions both on fuel and on feed water

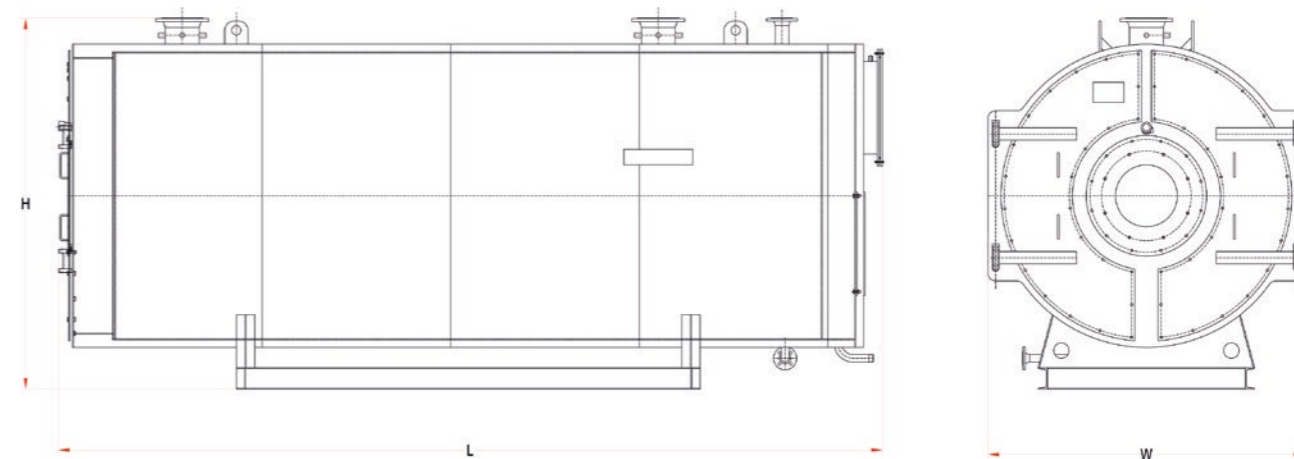
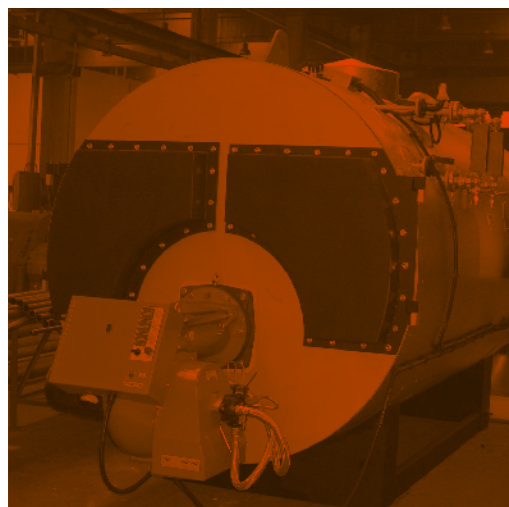

PRODUCT

- Water heater, fire tube, 3 passes, up to 16barg

TYOLOGY

- Fire tube • 3 passes • Wet back • Through furnace • Horizontal

CAPACITY

3,000 kW – 20,000 kW

**TECHNICAL DATA
THREE PASSES SMOKE SUPERHEATED WATER BOILER**

GPT/AS

TYPE		GPT/AS									
		2000	3000	4000	5000	6000	8000	10000	12000	14000	
Net power	kW	2,000	3,000	4,000	5,000	6,000	8,000	10,000	12,000	14,000	
Water content	liters	4,279	5,200	6,325	6,760	10,600	11,880	15,500	17,500	20,500	
Heating surface	m ²	75	82	98	128	174	212	268	302	342	
Water pressure drop	mbar	100	100	100	110	100	110	170	250	260	
Furnace pressure drop	mbar	9.0	10.0	10.5	11.0	11.0	13.0	13.5	14.0	17.0	
Empty weight 10bar	kg	327	299	330	385	439	526	617	670	764	
Empty weight 16bar	kg	338	312	368	415	475	554	679	685	782	
Stack connection diam.	mm	550	550	600	700	700	800	900	900	1,000	
Water in/out connect.	DN	DN200	DN200	DN200	DN200	DN250	DN250	DN250	DN300	DN300	
Length (body only)	mm	3,996	4,910	5,152	5,422	6,132	6,432	6,452	6,732	7,332	
Width (body only)	mm	1,950	1,950	2,020	2,100	2,350	2,480	2,800	2,900	3,000	
Height (body only)	mm	2,370	2,370	2,370	2,450	2,700	2,900	3,300	3,400	3,500	

Data for the sizes bigger than 14000 supplied on request



HEAT RECOVERY
HEATERS AND
BOILERS

**HEAT RECOVERY
HEATERS AND
BOILERS**

We design and manufacture recuperators for heat recovery for different types of industrial and marine applications. Our recuperators use exhaust fumes from motors, electric generators, ovens, incinerators and other industrial processes and transfer heat to a secondary fluid, which can be steam, water, diathermic oil or even air.

Each individual recuperator is specifically designed for its specific destination, based on the quantities, temperature and chemical / physical characteristics of the fumes, as well as taking into account the performance requirements and any dimensional or environmental constraints. Various construction types can be realized: one or more passes, coil type, or with bundles tubes smooth or finned. Large steam generators are also produced, water tube type, natural or forced circulation. Orientation can be both horizontal and vertical.

The recuperators are remarkably customizable, as well as from the point of view of the sizing and yield of the equipment, the control and the management system. All generators are designed, tested, built according to the latest regulations and can be certified according to PED, ASME, naval or other regulations depending on the country of installation.

The installation of a recuperator guarantees remarkable energy savings and helps reduce the emissions of harmful and greenhouse gases into the atmosphere.

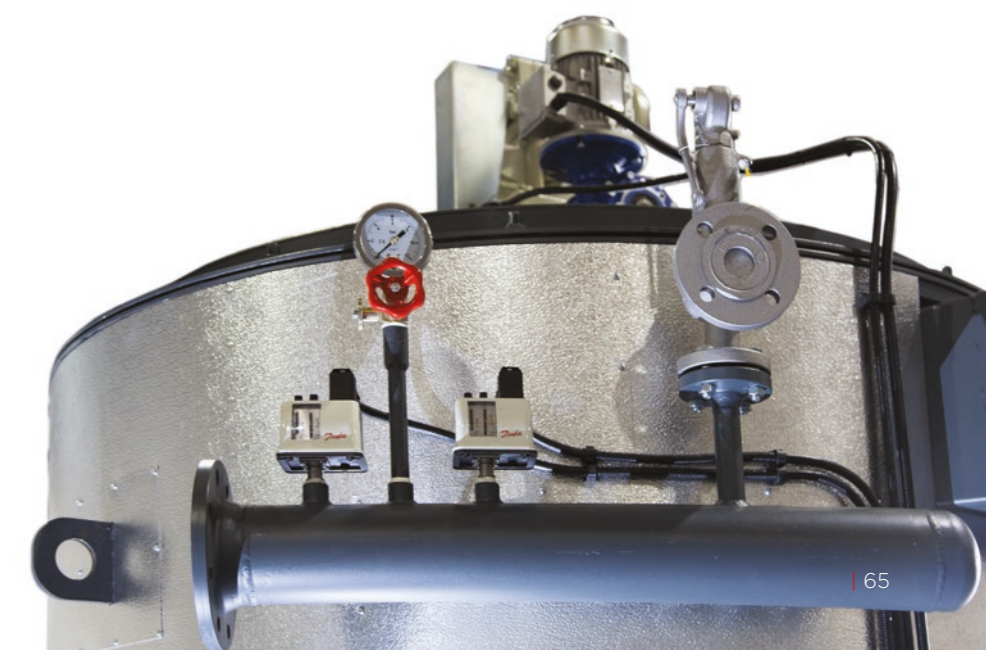

SYSTEMS FOR
COGENERATION

**SYSTEMS FOR
COGENERATION**

We support companies for the realization of cogeneration plants, with simultaneous production of electricity and heat.

The company can act as a component supplier, in particular boilers, or possibly as a manufacturer of the entire plant in turn-key mode. Solutions based on traditional fuels, biomass, or heat recovery are realized. All generators that are part of cogeneration plants are designed, tested, built according to the latest regulations and can be certified according to PED, ASME, naval or other standards depending on the country of installation.

The management and control systems are implemented in accordance with the most up-to-date standards and can provide innovative features such as tele-control or cloud mode for more convenient and secure use.



WATER TUBE BOILERS

WATER TUBE BOILERS

For steam generation in large installations or in particularly heavy applications, water tube boilers are the ideal solution. With this type it is possible to produce up to 50 Ton/h of steam, saturated or superheated, with pressures up to 50 barg.

Since work conditions can be significantly variable in terms of pressure, temperature, flow rate, fuel or heat source, these devices are typically tailor-made for specific applications. The constructive features are defined on the basis of actual needs and can include smooth or finned tubes, natural or forced circulation, horizontal or vertical orientation. They can be a direct flame or heat recovery from flue gases originated by external sources such as combustion of biomass, incineration or industrial processes.

The control system is also provided for a fully automatic and safe operation of the equipment. All generators are designed, tested, built on the basis of the latest regulations and can be certified according to PED, ASME, marine or other standards depending on the country of installation.



PLANTS
ACCESSORIES

**PLANTS
ACCESSORIES**

We design and manufacture various types of complement accessories for steam, water and thermal oil.

The main products are:

MODEL	TYPE	MIN CAPACITY	MAX CAPACITY
ATH	Atmospheric thermophysical degasser for condensate collection and boiler water supply. It is equipped with an automatic heating system, made by steam injection, to maintain water at a temperature of 90-95°C and thermodynamically remove most of the oxygen. Complete with external insulation.	800 liters	20,000 liters
FW	Water tank and condensate collection, vertical or horizontal. It can be made of both carbon steel and stainless steel.	300 liters	6,000 liters
BD	Blow down collection tank. It contains an automatic cooling system that allows you to bring the water below the permissible temperature before discharging it. Vertical configuration.	150 liters	2,000 liters
G	Steam accumulator, made horizontally or vertically. Complete with external insulation.	500 liters	18,000 liters
VES	Expansion vessel for thermal oil or water. It can be realized in atmospheric or pressurized version, vertical or horizontal. Complete with accessories.	200 liters	6,000 liters
FW	Oil storage tank, horizontal, for earthed or surface installations	300 liters	15,000 liters



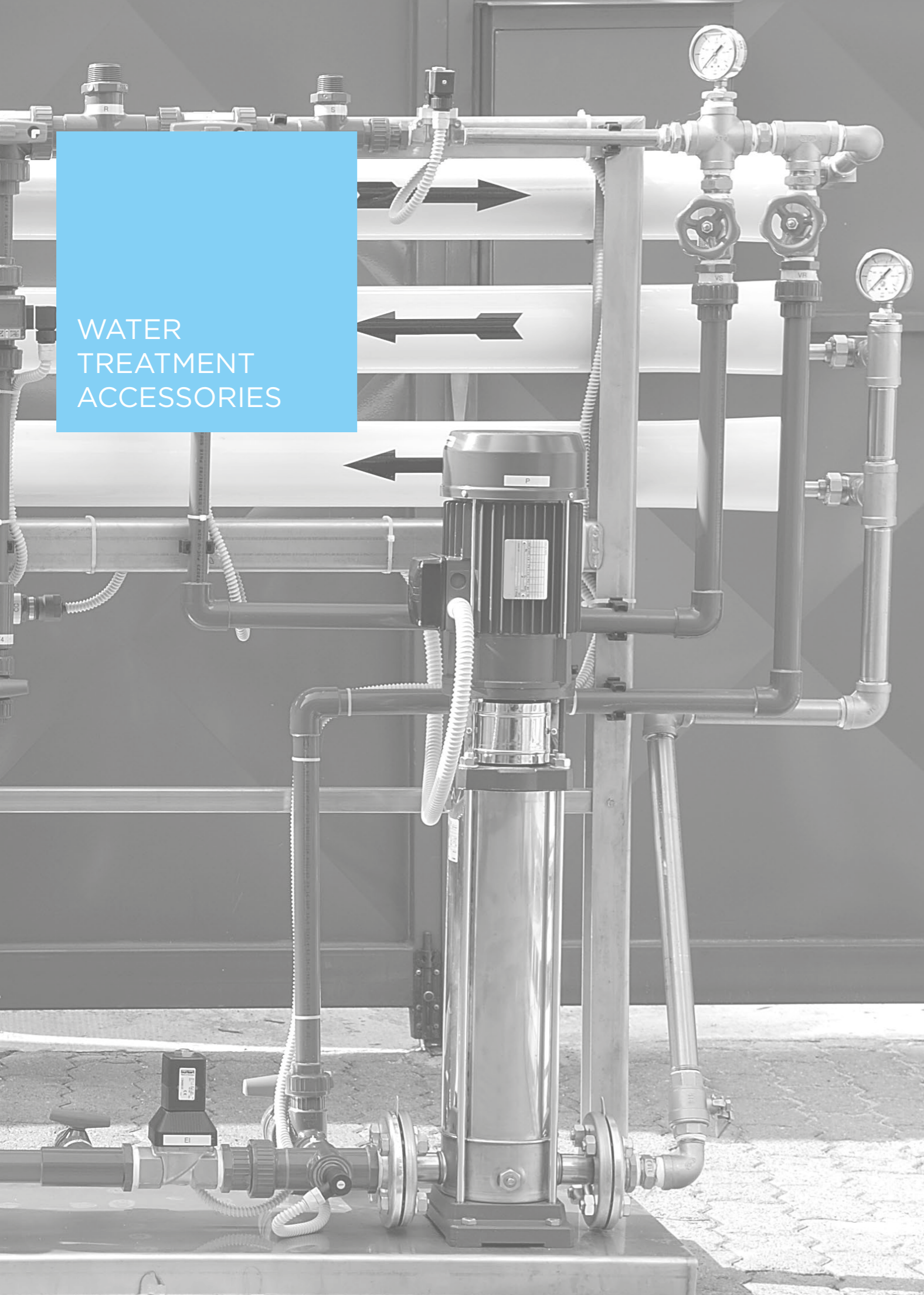

WATER
TREATMENT
ACCESSORIES

**WATER
TREATMENT
ACCESSORIES**

The quality of feed water is of great importance for the smooth operation and duration of the steam generators and for this reason we provide the equipment needed for this purpose.

Are available:

- Single and double column water softeners, complete with brine tank
- Dosing pumps for conditioning products, complete with collection tank
- Conditioning products in 25 kg bags
- Filters
- Water counters
- Reverse osmosis plants



TECHNICAL ASSISTANCE

TECHNICAL ASSISTANCE

Customer satisfaction and efficiency of the technical pre and post sales service are considered top priorities for us. Our service does not end with the sale of the boiler, but we support our customers at every stage of the purchasing process, from the analysis of every single request and requirement up to the study of customized solutions, from the initial consult to the final training on the use of our several heating systems.

We dedicate a team of experts to customer service, able to solve the most various problems that arise to customers. We take care to keep the boilers operating as long as possible, to provide for a preventive service and maintenance programs, and to ensure a quick intervention in case of failures. We guarantee the prompt delivery of original spare parts, with possible assistance during installation, thanks to an efficient warehouse order system.

Our technical assistance service is precise and reliable, with qualified and experienced personnel ready to take action for any type of need or emergency.

It is only in this way that we can be the single point of contact for our customers.

TECHNICAL ASSISTANCE



**THE BENEFITS
IN SUMMARY:**

- **Global consulting:** a team of professionals will analyse all the problems related to your heating system, from the study of the plant to the management of the boiler room.
- **Maintenance program:** a programmed maintenance system will allow to maintain your plants in excellent state, to extend its guarantee, to optimize the consumptions and avoid production interruptions.
- **Rapid response:** for those who adhere to the “scheduled maintenance” formula, we guarantee intervention priorities, where possible within 24 hours from the request.
- **Guaranteed spare parts:** certainty of original spares, spare parts always available, rapid delivery.
- **Reduced costs:** the general control and complete cleaning program guarantees longer system life, lower consumptions and lower extraordinary maintenance costs.

Contact us for any design development and cost estimate enquiry, sales and installation, training, start-up and commissioning, scheduled maintenance, technical service and spare parts.

TECHNICAL ASSISTANCE



**RESEARCH AND
DEVELOPMENT**

We are constantly expanding, we are a company based on constant growth and innovation, both from a technological and commercial point of view.

We have the world as border. And we cross it every day with our skills, which include engineering, production, logistics, installation, testing and technical assistance. All this to be able to design and to build heating systems more and more in line with market demands and customer expectations, with an eye constantly focused on environmental protection and sustainable development.

Our departments, from the commercial one, the assistance, the production, the purchases, are constantly evolving. This is especially true for Technical Department, which has grown a lot in recent years with the addition of highly experienced, constantly trained and updated personnel. More and more, in fact, it is asked to design the entire system, not more than the individual boiler.

Qualified professional figures are therefore necessary, able to assess the client’s needs, recommend the type of boiler, its potential, the sizing of the pipes, the different types of regulation and control equipment most suitable.



Close contact with the customer has enabled us to optimize the product range over the years, fostering what proved to be the strengths of the individual products, and improving the specificity of the individual machines, in order to propose an increasingly competitive from a technical standpoint and also economic.

Optimization of the systems we aim very, convinced that the greatest energy recovery lies precisely in reducing waste and minimizing environmental impact.

TECHNICAL ASSISTANCE



Primo Maggio
Testimoni di Geova →

via 1° Maggio
BREVE INDIZIONE →

© SVEGO

**Visit our website
to find out Garioni Naval
products and news:**

www.garioninaival.com